

JuiceBox Pro

User Manual

ENGLISH



Table of contents

Welcome to JuiceBox Pro	3
Package Contents	3
Required Tools	3
Installation	4
Installation Prerequisites	4
Installation	5
Load Balancing	8
Locking Your JuiceBox	9 9
Wi-Fi Setup	11
	11
JuiceBox Configuration	16
Configure JuiceBox Using Bluetooth Connectivity	
Configure JuiceBox Using Wi-Fi Connectivity	21
	21
Specifications	21
Characteristics	22
Connectivity	
Dimensions	24
LED Indicator	25
	25
Using the Dashboard	25
Enterprise Dashboard Manual	
Business Dashboard Manual	25
	25
RFID Cards	25
RFID Reader	
Activating And Managing	26
Important Safety Information	26
	27
FCC Compliance	
RF Exposure	

Welcome to JuiceBox Pro

Package Contents

- > JuiceBox



NOTE: In some markets, JuiceBox arrives secured to a cable holder that includes keys.

- > Wall bracket
- > 2 wall bracket screws (#10 self-tapping Phillips head wood screws)
- > 2 screws to hang JuiceBox onto wall bracket (#10-32 Phillips head machine screws)
- > 1 RFID card (except 80A)

Required Tools

- > Phillips Screwdriver (No. 2 drive size)
- > Stud sensor
- > Stripper
- > Wire nut or wire coupler
- > Allen key
- > Electrical tape
- > Wrench or torque wrench

Installation

Installation Prerequisites

OVERVIEW

JuiceBox requires either a hardwired electrical connection or a NEMA 14-50 outlet.

The JuiceBox power supply must be connected to a circuit breaker that is rated for at least 125% of the device's continuous load.



NOTE: Ensure that all power connection wiring conforms to the rules and regulations of any national and local codes.

- > The JuiceBox may require a disconnecting means if:
 - > Not within line of sight of the Electrical Panel
 - > Required by local code
 - > **Hardwire Version:** Only the pre-installed, hard wire whip shall be used to connect to a junction box or disconnect. It is not long enough, nor is it meant to go directly into the electrical panel.



CAUTION: Do NOT drill any additional holes into the JuiceBox enclosure as it can cause damage to the PCB and/or electronics inside.

LOCATION

When selecting a location to install the hardwire connection or outlet, keep in mind that JuiceBox should be positioned:

- > Within reach of the vehicle's charge port
- > 18 inches above the floor or ground
- > If applicable, within range of a cellular connection or the local Wi-Fi network

WIRING AND CIRCUIT REQUIREMENTS

For additional specifications, refer to the [Specifications](#) section.

	32A	40A	48A	80A
CIRCUIT REQUIREMENTS	40 Amp 2 pole breaker	50 Amp 2 pole breaker	60 Amp 2 pole breaker	100 Amp 2 pole breaker



NOTE: For the installation wiring, please have your electrician size the conductors for both rated wire temperature and 125% continuous load. Please refer to both the National Electrical Code (NEC) and your local Authority Having Jurisdiction (AHJ) for any additional requirements.¹

¹
The neutral wire is not used, but may need to be present in the receptacle.

Installation

Fully read and understand the directions before installation. Refer to [important safety information](#) at the end of this document.

This section describes installing the JuiceBox Pro onto a wall mount. If installing onto

a _____
JuiceStand, refer to the [JuiceStand Manual](#).

1. Turn off the circuit breaker to the NEMA 14-50 outlet, NEMA 6-50 outlet, or hardwired electrical connection.



WARNING: Do not continue this installation until the circuit breaker is turned off.

2. Use a stud sensor to determine an appropriate mounting location, then use the 2 screws to secure the wall bracket.

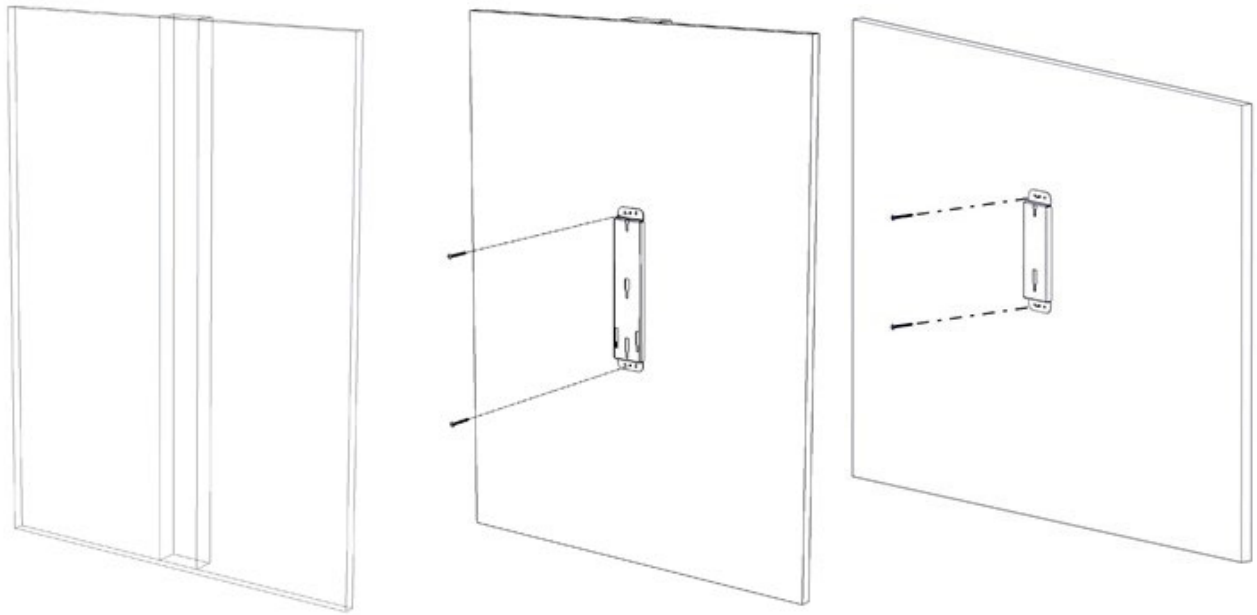

	Version with cable holder	Version without cable holder
--	----------------------------------	-------------------------------------

3. Insert the enclosure screws into the enclosure, as shown. Tighten the screws until approximately 2 mm of thread are visible.

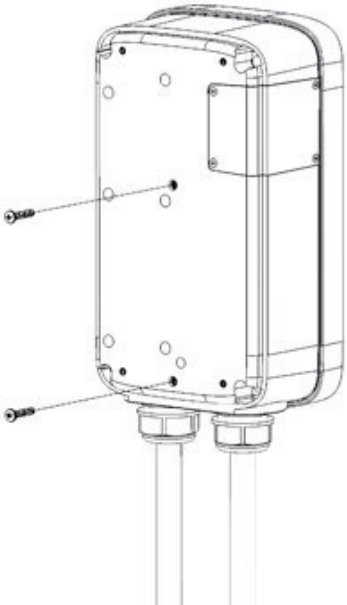
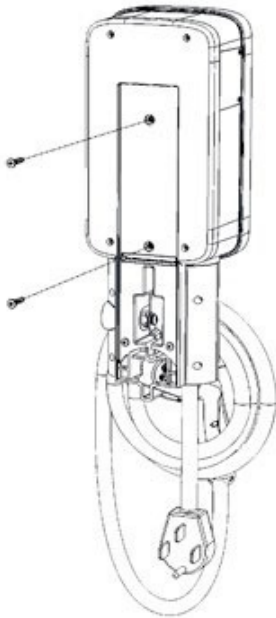

Version with cable holder	Version without cable holder
----------------------------------	-------------------------------------

4. Hang the JuiceBox onto the wall bracket.



NOTE: If the JuiceBox does not hang securely, adjust the screws that were installed in step 3. The 48 and 80 amp are hardwire only and do not have a plug as shown.

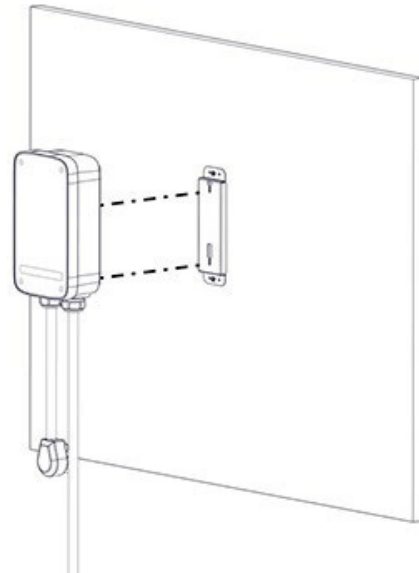
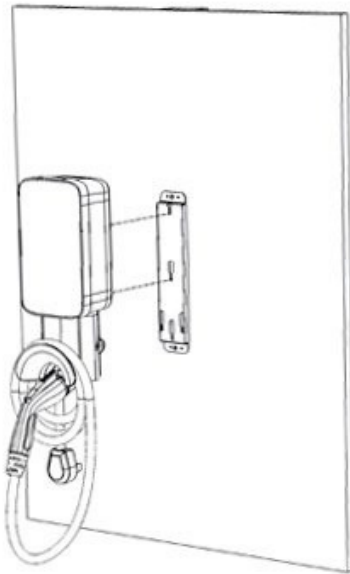

Version with cable holder

Version without cable holder

5. Connect the JuiceBox:

- > **Plug-In Version:** Plug the JuiceBox into the NEMA 14-50 outlet or NEMA 6-50 outlet.
- > **1-Phase Hardwired Version:** Connect the harness to the junction box.



WARNING: It is the installers responsibility to ensure that the JuiceBox is wired in accordance with the local electrical code.



NOTE: For the installation wiring , please have your electrician size the conductors for both rated wire temperature and 125% continuous load. Please refer to both the National Electrical Code (NEC) and your local Authority Having Jurisdiction (AHJ) for any additional requirements. 1

1The neutral wire is not used, but may need to be present in the receptacle.



NOTE: The hardwire versions of the JuiceBox are shipped with appropriate wires that meet the National Electric Code (NEC) NFPA 70 and require a nearby junction box connection. Any alteration of the supplied wiring will invalidate the warranty and may not conform to NEC.

COLOR	SIGNAL
Black	L1
Red	L2
Green	Ground

6. Turn on the circuit breaker that supplies power to the NEMA 14-50 outlet, NEMA 6-50 outlet, or hardwired electrical connection.

Load Balancing

- > Load balance to Circuit only.
- > Load balance to panel is NOT recommended.



NOTE: Balancing to the panel or location can be done on a system that would otherwise work safely on its own. This can reduce usage during peak hours, saving cost to both the user and the owner of the stations.

- > Can only balance stations with the same specifications.
- > Balancing specifications cannot exceed the rated continuous load of the circuit. (50 amp circuit = 40 amp continuous load allowed) (NEC 625.41 & 42) 2017 code.
- > Per NEC 625.42 additional outlets per circuit can be added due to the JuiceNet Automated Load Management System.
- > Recommend no more than 3 per circuit. The maximum number of stations per circuit is determined by dividing the number of continuous load amps allowed based on circuit size by 8. (e.g. 40 amps / 8 amps = 5 stations maximum). Note this may result in a slower charge per car.

Locking Your JuiceBox

After installing your JuiceBox, use the included keys to lock the JuiceBox to the wall frame.

Wi-Fi Setup

 **NOTE:** Wi-Fi configuration is neither necessary nor recommended for JuiceBoxes that include cellular connectivity or that are assembled in a JuicePedestal that includes a payment terminal.

1. Reset the circuit breaker that supplies power to the JuiceBox.

 **NOTE:** The following steps must be completed within 2 minutes of reconnecting power to the JuiceBox. The JuiceBox will remain in setup mode for 4 minutes.

2. Open Wi-Fi settings on your personal device. Connect to the "JuiceBox-###" or "JuiceNet-###" Wi-Fi network. If the network requires a password, use the password "GoElectric" (case-sensitive).

 **NOTE:** The actual name of the network varies by device, such as "JuiceBox-123".

3. In a web browser, navigate to 10.10.10.1 or to setup.com to view a list of available Wi-Fi networks.

 **NOTE:** If there are problems connecting, ensure that the following addresses are not blocked:

IP ADDRESS	PROTOCOL	PORTS	FQDN
dynamic	HTTPS	443	directory-api.emotorwerks.com
dynamic	HTTPS	443	ota.zentri.com
dynamic	HTTPS	443	dms.zentri.com

138.91.137.23	UDP	8042	jbv1.emotorwerks.com
40.118.171.20	UDP	8042	emwjuicebox.emotorwerks.com
dynamic	HTTPS	443	device-backend.juice.net



4. Select the desired Wi-Fi network. Enter the Wi-Fi network password, if necessary. Click **Connect**.

Verify that the JuiceBox is connected by checking that the LED indicator turns white.

JuiceBox Configuration

For best results, perform this procedure while standing within 5 ft (1.6m) of the JuiceBox.

Configure JuiceBox Using Bluetooth Connectivity

***REQUIRES FIRMWARE 1.0.46 OR LATER**

1. Download and install the “JuiceConfigure” app onto your mobile device.



Video walkthrough of this section



2. Open the **JuiceConfigure** app.



NOTE: Make sure your phone and JuiceBox’s Bluetooth connection is enabled before starting to be able to configure Wi-Fi for your charger.

3. Select **START CONFIGURATION**.

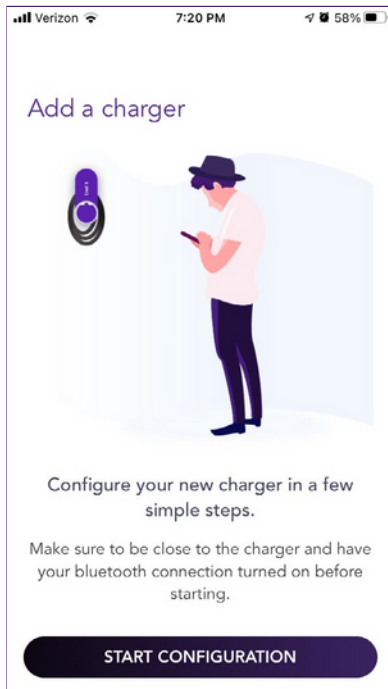

4. Follow the onscreen instructions to proceed to JuiceBox configuration.

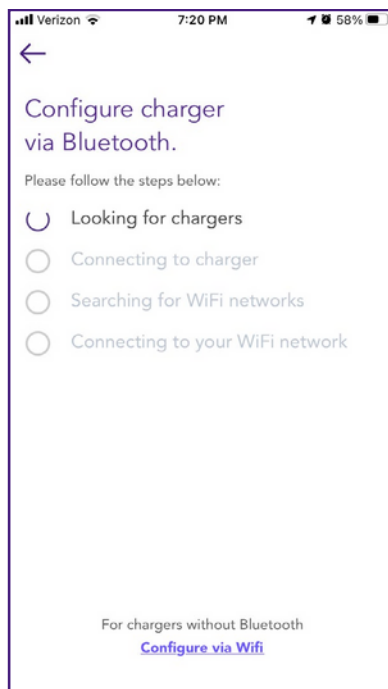

5. Chargers are scanned and listed on the screen. Select **Pair** to configure the charger.

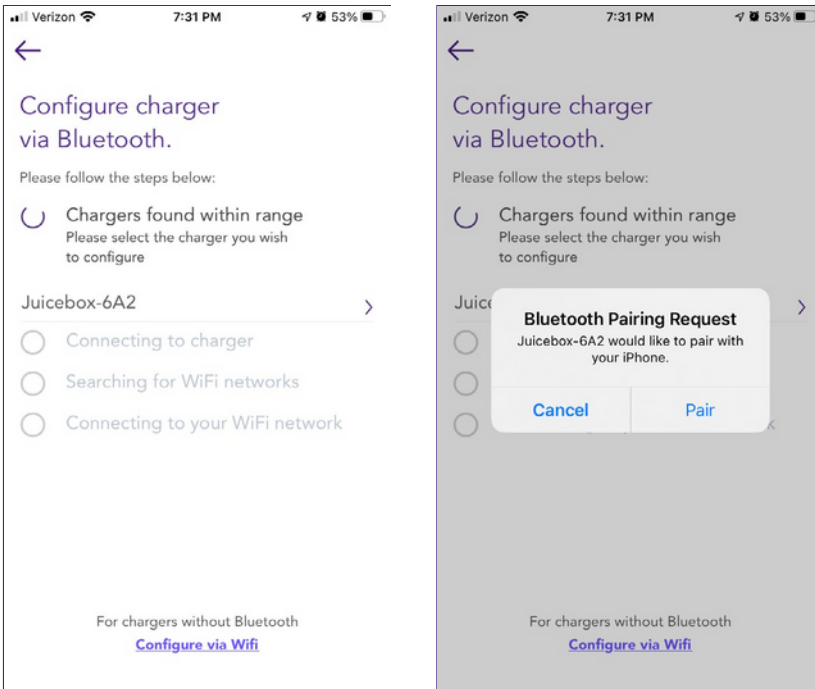

6. Your JuiceBox is now connected to your account.

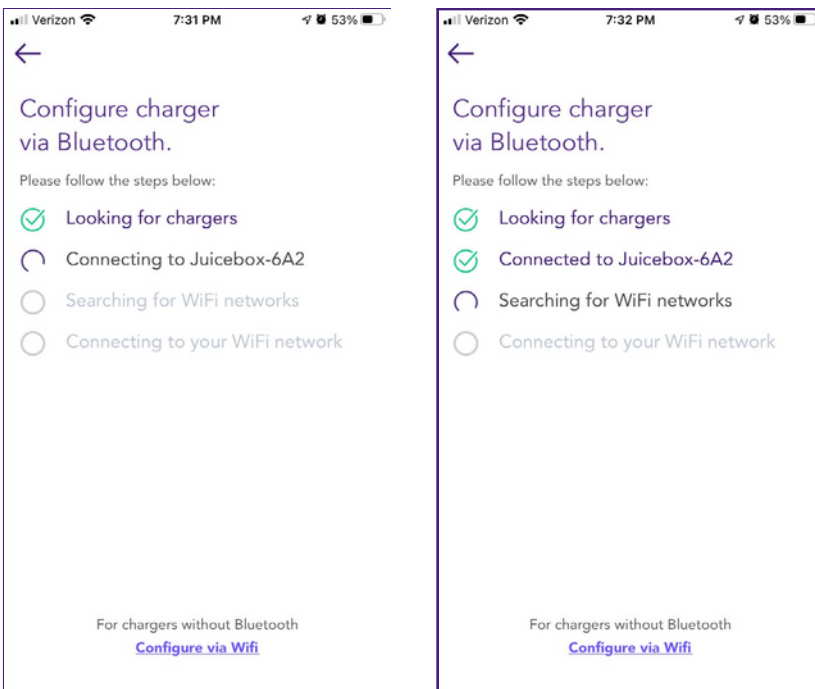

7. Wi-Fi networks are scanned and listed on the screen. Select the network you want to connect your JuiceBox to.

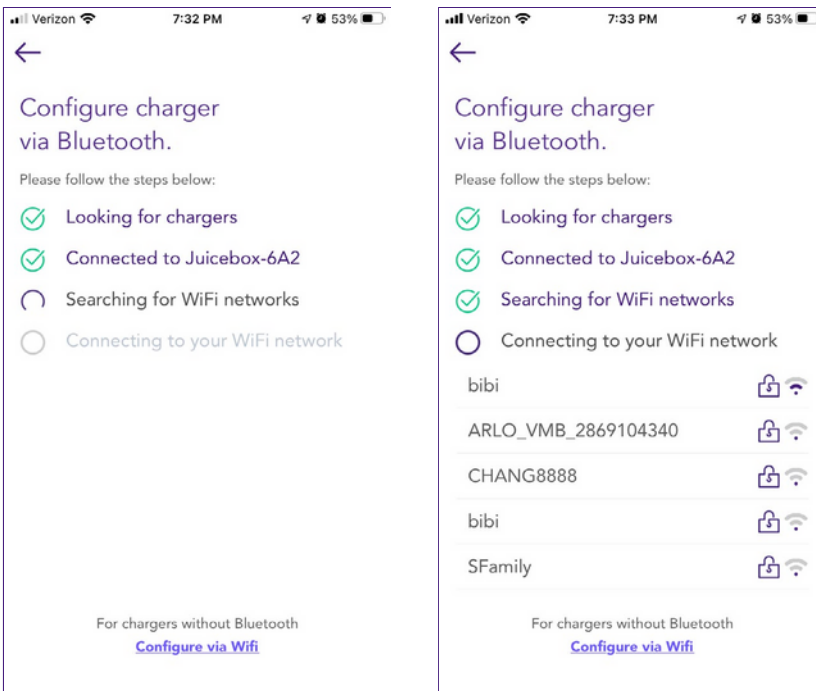

8. Enter the password of the selected Wi-Fi network and select **Connect charger to Wi-Fi**.

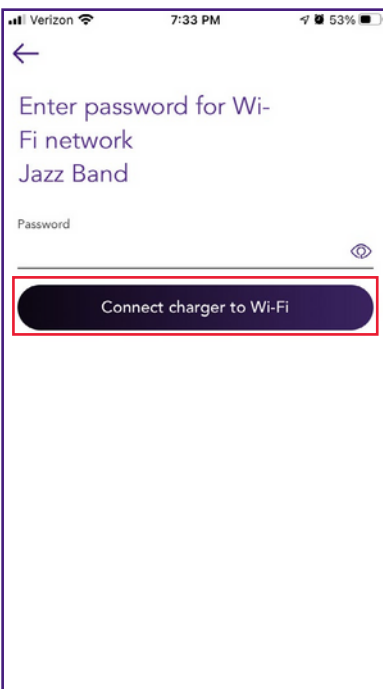

9. The JuiceBox is connected to your account. Select **CONTINUE**.

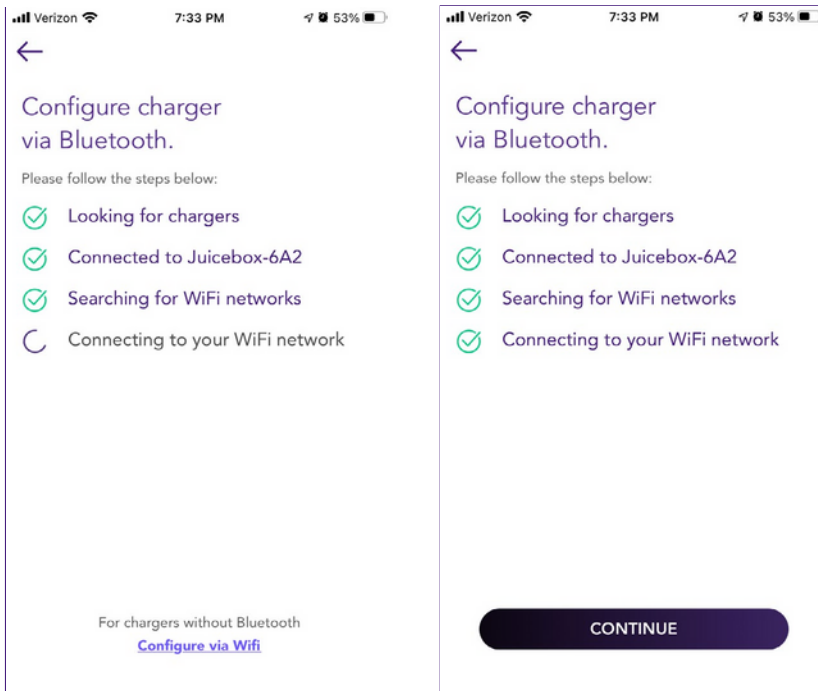

10. In the configuration screen, set the **maximum current** for charger at which you want to charge your vehicle, then select **SAVE**.

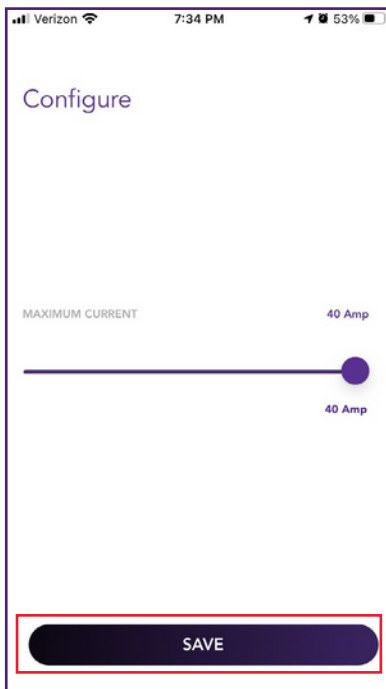

NOTE: After connecting, JuiceBox checks its firmware version and performs any necessary updates. Wait 10 minutes before plugging in a vehicle.

Configure JuiceBox Using Wi-Fi Connectivity

1. Download and install the “JuiceConfigure” app onto your mobile device.



Video walkthrough of this section



2. Open the **JuiceConfigure** app.

3. Select **START CONFIGURATION**.

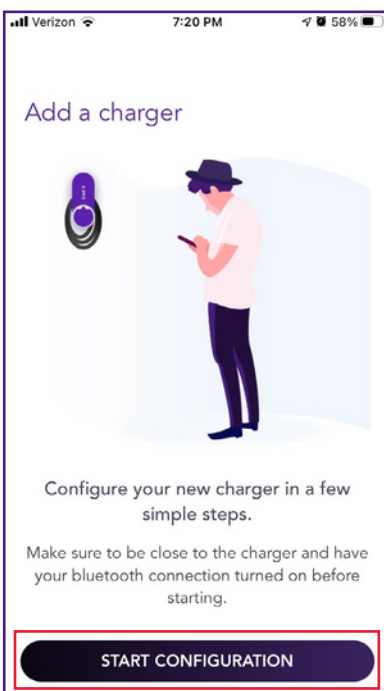

4. Select **Configure via Wifi**.

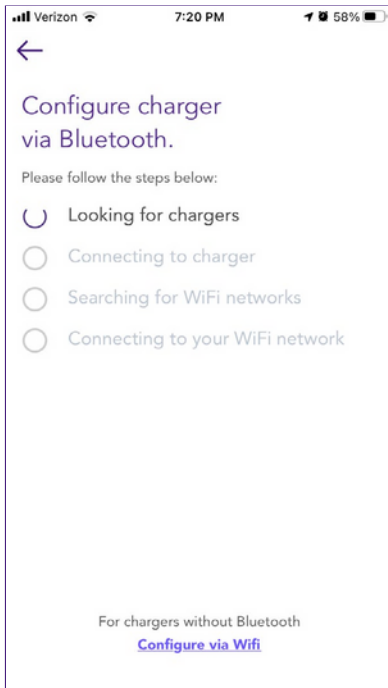

5. Have the Wi-Fi network password ready, then select **NEXT**.



NOTE: If the JuiceBox is already power on before this step, disconnect it from power and re-connect again before proceeding.

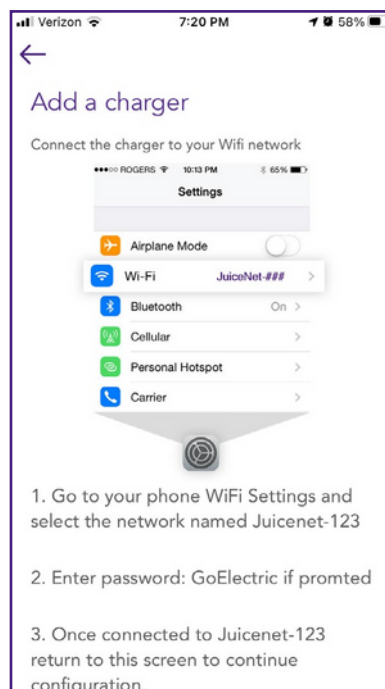
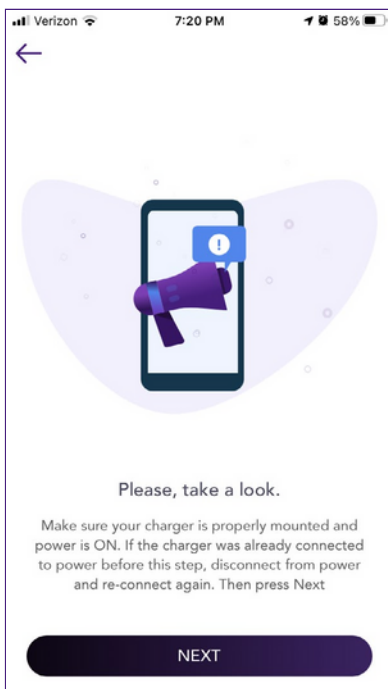

NOTE: After powering the JuiceBox, complete the steps 6 through 9 within 2 minutes.

6. Navigate to the Wi-Fi settings on your mobile device. Connect to the “JuiceBox-###” or “JuiceNet-###” Wi-Fi network. If the network requires a password, use the password “GoElectric” (case-sensitive).



NOTE: The actual name of the network varies by device, such as “JuiceBox-123”.

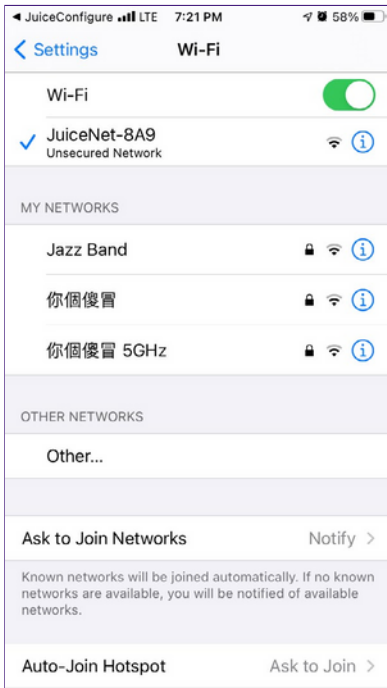

7. Return to the **JuiceConfigure** app.

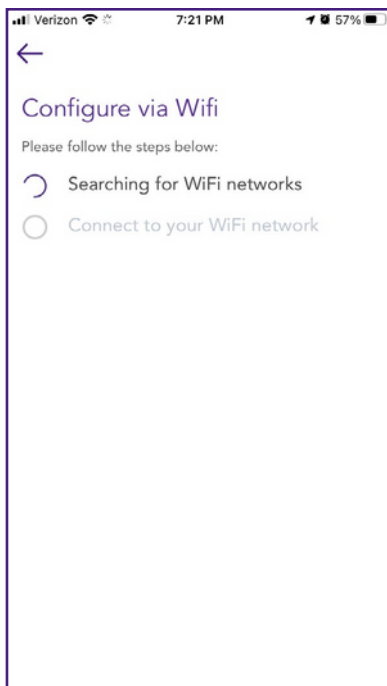

8. In the **JuiceConfigure** app, select the preferred local Wi-Fi network.

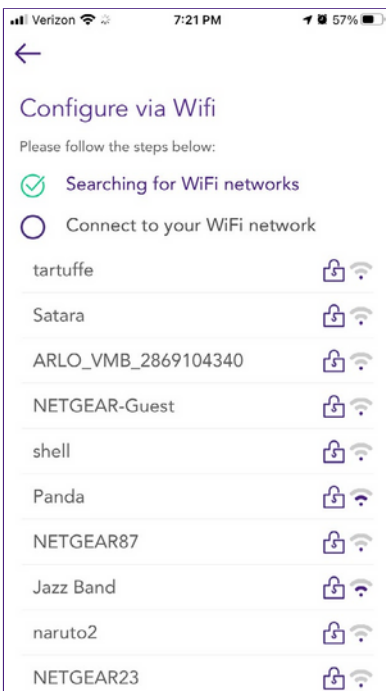

9. Enter the Wi-Fi network password, if necessary, then select **CONNECT CHARGER TO WI-FI**.



10. The app connects the JuiceBox to the Wi-Fi network, then select **CONTINUE**.

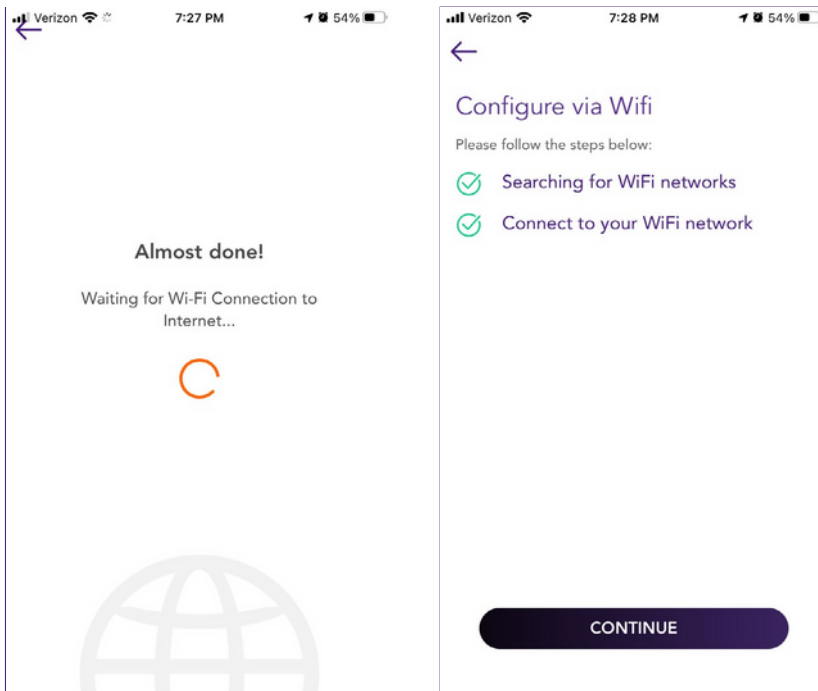

11. You did it! The JuiceBox is now online and ready to charge.

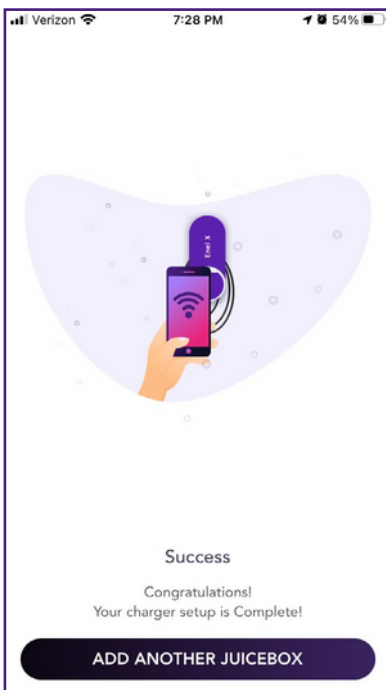

NOTE: After connecting, JuiceBox checks its firmware version and performs any necessary updates. Wait 10 minutes before plugging in a vehicle.

Specifications

Characteristics

OUTPUT POWER	32A max: Up to 7.7 kW, 32A, 1-phase
	40A max: Up to 9.6 kW, 40A, 1-phase
	48A max: Up to 11.5 kW, 48A, 1-phase
	80A max: Up to 19.2 kW, 80A, 1-phase
INPUT VOLTAGE	208 or 240 VAC
CHARGING MODE	Mode 3
LEDS	Dynamic LEDs displaying charging status
PROTECTION	IP67
	AC 20mA Ground Fault Detection
TEMPERATURE RANGE	From -40°C to +60°C
STANDARDS AND CERTIFICATION	IEC 61851-1
	UL Certified

Connectivity

WI-FI	IEEE 802.11b/g/n 2.4 GHz
(OPTIONAL) CELLULAR	LTE (CAT-1) Bands B2, B4, B5, B12/B13
3G	Bands B2 (1900), B5 (850); PTCRB and GCF certification

Dimensions

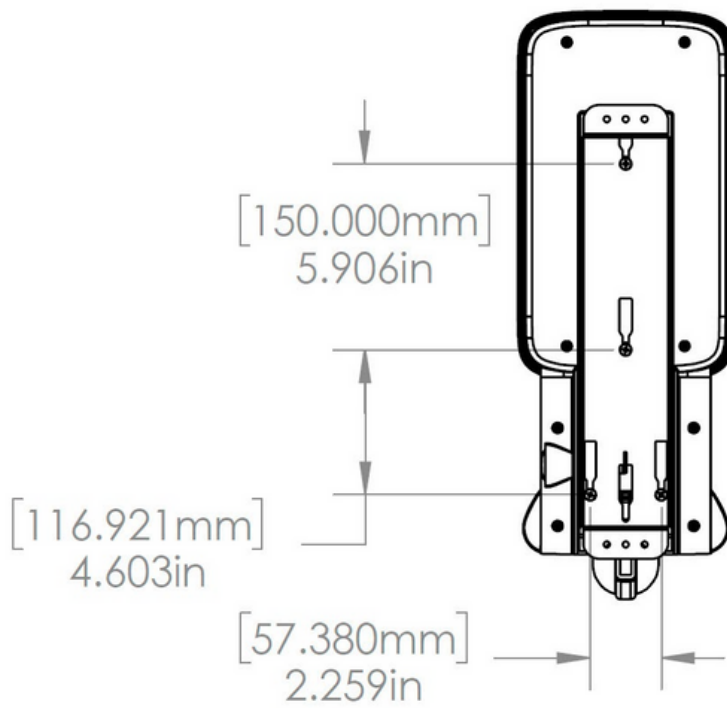
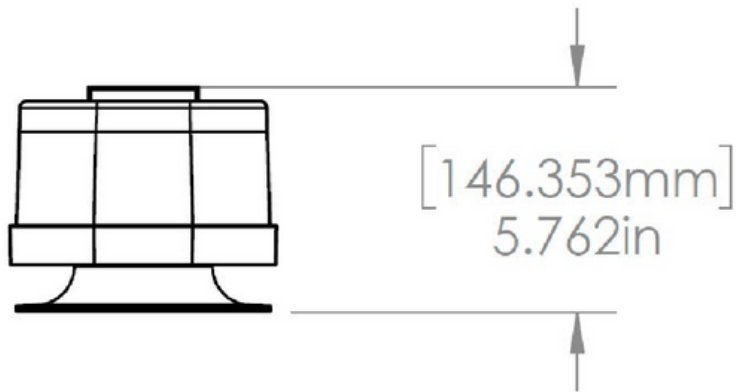

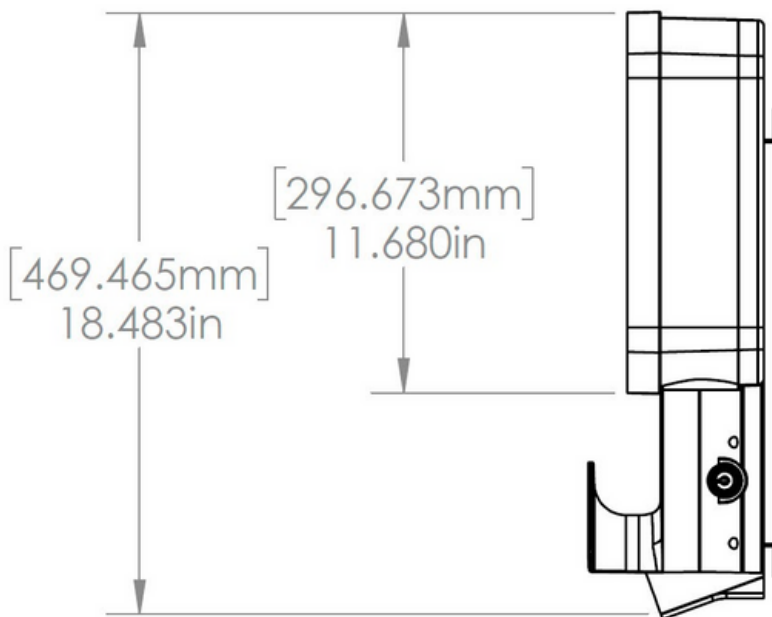
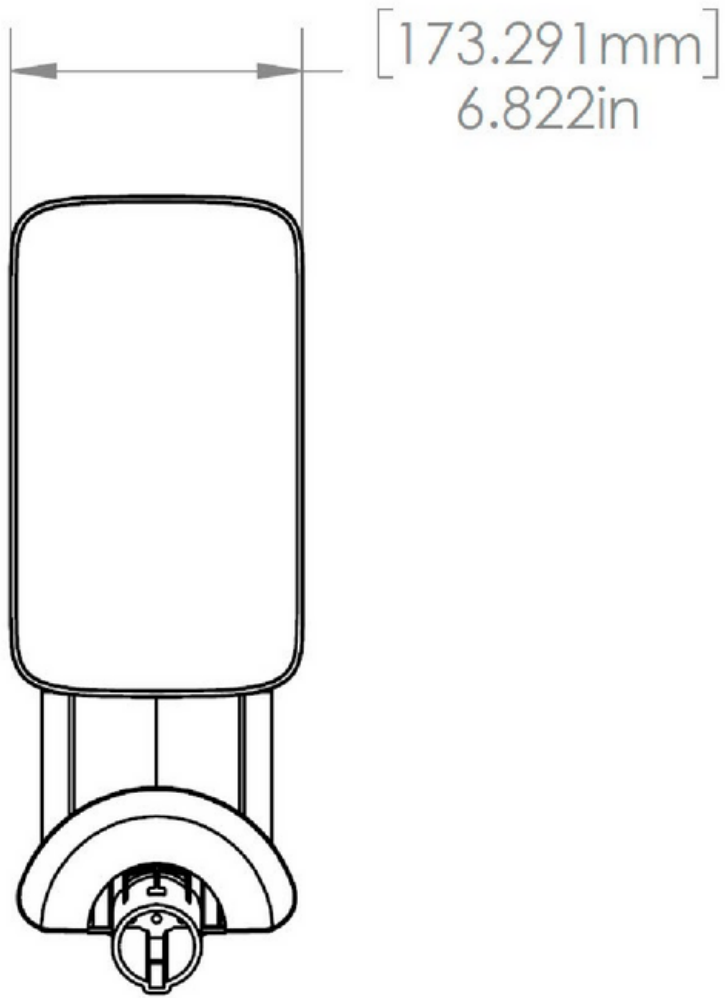

LED Indicator

COLOR	PATTERN	MEANING
Blue	Flashing	Setup Mode
Yellow	Solid	Booting after power (Note: During booting, solid Yellow may be followed by Purple before going to Setup Mode)
	Flashing	Vehicle plugged in, not charging (Note: EV not ready to charge or charging suspended (ToU) or in earlier releases: charging finished)
White	Solid	Online: Idle, vehicle not plugged in
		Offline: Idle, vehicle not plugged in
Purple	Solid	Vehicle finished charging
Green	Solid	(Note: Firmware release 1.0.30 only.) RFID authorized
	Long Flash (5-sec duration)	
	Flashing	Vehicle charging
Red	Flashing	Error (Refer to error codes)

Using the Dashboard

Enterprise Dashboard Manual

To access the JuiceNet Enterprise documentation and FAQs, log into your [Enterprise account](#).

Business Dashboard Manual

To access the JuiceNet Enterprise documentation and FAQs, log into your [Business account](#).

RFID Cards

RFID Reader

IP ADDRESS	PROTOCOL	PORTS	FQDN
dynamic	HTTPS	443	directory-api.emotorwerks.com
dynamic	HTTPS	443	ota.zentri.com
dynamic	HTTPS	443	dms.zentri.com
104.40.90.102	UDP	8042	jbv1.emotorwerks.com
40.118.171.20	UDP	8042	emwj Juicebox.emotorwerks.com
dynamic	HTTPS	443	device-backend.juice.net

Activating And Managing

Refer to the [RFID Cards](#) section of the JuiceNet Enterprise Manual.

Important Safety Information

Read all safety information before installing this product.

WARNING: This device should be supervised when used around children.

WARNING: Do not put fingers into the electric vehicle connector.

WARNING: Do not use this product if the flexible power cord is frayed, has broken insulation, or shows any other signs of damage.

WARNING: For use with electric vehicles only.

WARNING: Do not use this device with an extension cord.

WARNING: Do not remove cover or attempt to open the enclosure. No user serviceable parts inside. Refer servicing to qualified service personnel.

WARNING: Install and use away from flammable, explosive, harsh or combustible vapors, materials or chemicals.

WARNING: Do not operate outside temperature rating of -40°C to +60°C.

WARNING: This device is intended only for electric vehicles not requiring ventilation during charging.

WARNING: This product must be grounded. If it should malfunction or break down, grounding provides a path of least resistance for electric current to reduce the risk of electric shock.

WARNING: Improper connection of the equipment-grounding conductor is able to result in a risk of electric shock. Check with a qualified electrician or serviceman if you are in doubt as to whether the product is properly grounded.

FCC Compliance

This equipment has been tested and found to comply with the limits for a Class B digital device, pursuant to part 15 of the FCC Rules. These limits are designed to provide reasonable protection against harmful interference in a residential installation. This equipment generates, uses and can radiate radio frequency energy and, if not installed and used in accordance with the instructions, may cause harmful interference to radio communications. However, there is no guarantee that interference will not occur in a particular installation. If this equipment does cause harmful interference to radio or television reception, which can be determined by turning the equipment off and on, the user is encouraged to try to correct the interference by one or more of the following measures:

- > Reorient or relocate the receiving antenna.
- > Increase the separation between the equipment and receiver.
- > Connect the equipment into an outlet on a circuit different from that to which the receiver is connected.
- > Consult the dealer or an experienced radio/TV technician for help.



WARNING: Changes or modifications not expressly approved by the party responsible for compliance could void the user's authority to operate the equipment.

RF Exposure

The antennas must be installed so as to maintain at all times a distance minimum of at least 20 cm between the radiation source (antenna) and any individual. This device may not be installed or used in conjunction with any other antenna or transmitter.