

# noodoe



## DC180P User Manual



Dust and Water  
Protection MEMA 3R



Authorization



Management



Easy  
Maintenance



Easy Installation

[techsupport@noodoe.com](mailto:techsupport@noodoe.com)

COPYRIGHT © 2023 Noodoe Corporation reserves the right to  
make changes to this product without further notice.

Version 1.0A



# CONTENTS

Introduction / User Experience / Noodoe EV Operating System (EV OS) / Autonomous Revenue Generation .....	2
Pricing / User Management /Extensibility .....	3
<b>1. Basic User Interface .....</b>	<b>4</b>
<b>2. Specifications .....</b>	<b>5</b>
2.1 Product Specification .....	5
2.2 DC180P Version Description .....	8
2.3 LED Indication and Operation Status .....	9
2.4 Dimensions .....	10
2.5 Direction of Cooling Airflow .....	10
<b>3. Installation Instructions .....</b>	<b>11</b>
3.1 Before Installation .....	11
3.2 Grounding and Safety Requirement .....	17
3.3 Safty Shutdown .....	19
3.4 Unpack the Charger .....	21
3.5 Recommended Tools for Installation and Inspection .....	24
3.6 Installation Procedure .....	25
3.7 Installation Inspection and Commissioning .....	30
<b>4. Network Setting .....</b>	<b>33</b>
4.1 Wi-Fi Network Setting .....	33
4.2 3G/4G Setting .....	35
4.3 Time setting .....	37
<b>5. Activation Instructions.....</b>	<b>39</b>
5.1 Activation Overview .....	39
5.2 Prior to Activation .....	40
5.3 Creating a Site.....	41
5.4 Adding Charging Stations.....	42
5.5 Taking Charging Station Photos.....	42
<b>6. Operation Process .....</b>	<b>43</b>
6.1 Operating Sequence .....	43
6.2 Operating Procedure .....	43
6.3 Troubleshooting .....	50
6.4 Status Codes .....	58
<b>7. Maintenance .....</b>	<b>79</b>
7.1 General Maintenance .....	79
7.2 Replacement Kits and Accessories .....	82
<b>8. Limited Product Warranty .....</b>	<b>83</b>
<b>9. Federal Communication Commission Interference Statement .....</b>	<b>85</b>
<b>10. Industry Canada Statement .....</b>	<b>86</b>
 Appendix - Package List .....	 88

## **Introduction**

The Noodoe EV Exceed DC fast chargers offer the greatest convenience to both customers and service providers. These charging stations provide the quickest charge to battery electric vehicle (BEV) and plug-in hybrid electric vehicle (PHEV) drivers who want to get back on the road as soon as possible. DC fast chargers are becoming both more common and more sought-after by savvy EV drivers who don't want to wait hours for a full battery. They are excellently suited to fast-turnaround locations, such as highway service areas, gas stations, fleet charging stations, retail and commercial parking lots, work-places, and anywhere else looking to provide the fastest, most convenient charging experience. Exceed DC chargers are sturdy and can stand up to the elements. They are safety certified, and the design is both waterproof and dustproof. Install them anywhere without environmental concerns.

## **User Experience**

Exceed DC fast chargers are easy to engage with and use. They feature simple designs to make charging a truly painless experience. Clear buttons and interfaces help drivers plug in and go. Users can begin charging either through an authorized RFID smart card (perfect for fleets), the Noodoe mobile app, or our online web portal. Exceed DC chargers connect remotely with customers, offering real-time location, charging progress, and billing information.

## **Noodoe EV Operating System (EV OS)**

Noodoe EV OS is a cloud-based operating system that unifies the management of all Noodoe EV charging stations. It centralizes charger operation and streamlines the administration of the entire charging network. The EV OS dashboard pulls together information from every connected charger, providing a wealth of information right at your fingertips. Revenue generation becomes practically hands-free as EV OS implements your chosen settings. It even runs charging station diagnostics and self-repair protocols, dramatically reducing the need for expensive maintenance and repairs.

## **Autonomous Revenue Generation**

- Noodoe EV OS supports autonomous revenue generation by streamlining all aspects of EV charger management.
- Service providers have access to up-to-the-minute data on usage, monetization, power status, and more.

- Exceed DC chargers support universal, automatic pay-at-the-pump transactions through Apple Pay, Google Pay, credit cards, or the membership management program in Noodoe EV OS.
- Funds automatically transfer to the management-designated account.

## **Pricing**

- Connect chargers from multiple sites to a shared network in Noodoe EV OS, enabling pricing changes right from the EV OS dashboard.
- Change pricing and availability on the fly or via preset, automated schedules with the click of a button.
- Set pricing based on either time taken (price per minute) or energy (price per kW) usage.
- Enjoy set-it-and-forget-it automatic peak hour price changes.

## **User Management**

- Chargers can offer multiple pricing tiers through EV OS's integrated user management system.
- Users can make payments through at-the-pump mobile transactions or targeted membership plans for VIPs, special guests, residents, or staff.
- Membership management allows for charging to be available to a select few as a free amenity while still requiring payment by the wider public.
- Integrated user management is ideal for staff and fleet charging, leaving unused chargers available for public use.

## **Extensibility**

- Noodoe EV offers additional software services specially developed for a wide range of charging environments, including those for fleets, workplaces, residences, shopping centers, dealerships, gas stations, smart cities, and more.
- To support the different needs of our customers, Exceed DC chargers support both simultaneous charging and intelligent load balancing, distributing power across multiple vehicles on the same charger and across multiple chargers on the same network.
- Noodoe EV OS manages load balancing for all networked Noodoe EV chargers.

# 1. Basic User Interface

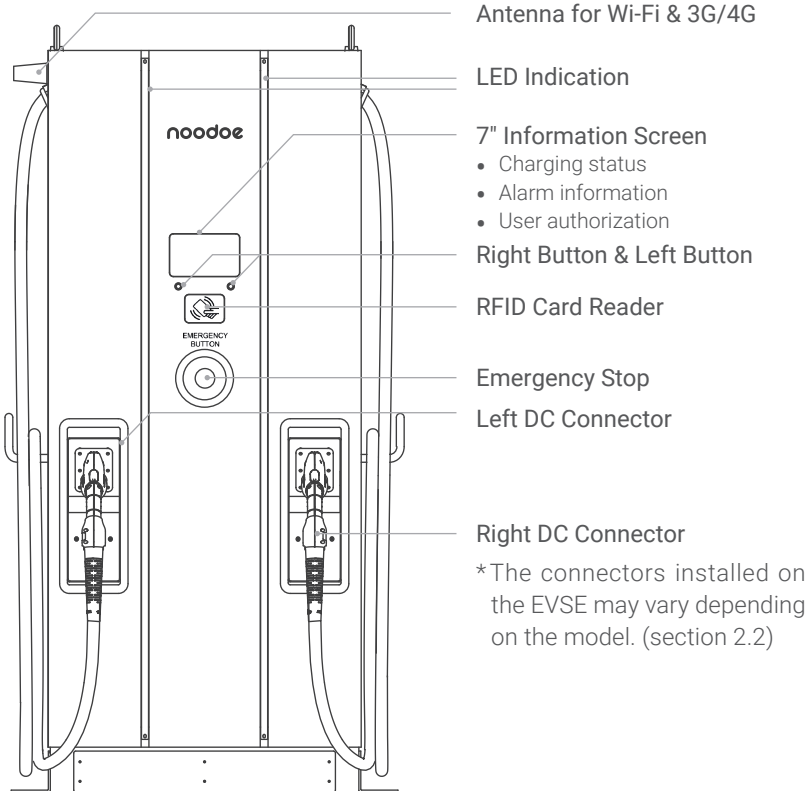

## Applications

- Public and Private Parking Areas
- Community Parking Areas
- Parking Areas of Hotels, Supermarkets, and Shopping Mall Parking
- Workplace Parking Areas
- Charging Stations
- Highway Rest Areas

## 2. Specification

### 2.1 Product Specification

Model Name		DC180P
AC INPUT	Voltage Rating	480 Vac (+10%, -15%), 3-phase
	Maximum Input Current	232 A @277 Vac, L-N 284 A @235 Vac, L-N
	Electrical Distribution	3P+ N+ PE (Wye configuration)
	Power Grid System	TN/TT and IT
	Frequency	50/60 Hz
	Maximum Input Power	194 kVA
	Power Factor	> 0.99
	Efficiency	> 94%, at optimize V/I point
DC OUTPUT	Dual Output	CCS1 and CHAdeMO
	Output Voltage Range	CCS1: 150 Vdc ~ 950 Vdc CHAdeMO: 150 Vdc ~ 500 Vdc
	Maximum Output Current	**CCS1 200 A @150 Vdc ~ 500 Vdc when output voltage up to 950 Vdc the output current is 190 A  **CHAdeMO 120 A @150 Vdc ~ 500 Vdc
	Maximum Output Power	DC 180 kW
	Simultaneously output mode	0% , 50% , 100% *Each connector will get 50% output power when plug in simultaneously; And one connector will get 100% when another connector finish the charging session or only this connector is plugged in.
	Voltage Accuracy	±2%
	Current Accuracy	±2%
Electrical Isolation	Isolation between Input and Output	
Standby Power	< 100 W	

Communication	External	Ethernet, Wi-Fi and 3G or 4G  <b>LAN:</b> support 10/10, 100/100 base <b>Wi-Fi:</b> support 2.4G <b>4G Frequency Band:</b> LTE FDD : B2/B4/B5/B12/B13/ B14/B66/B71 <b>3G Frequency Band:</b> WCDMA : B2/B4/B5
	Internal	CAN Bus/RS485
Input Protection	OVP, OCP, OPP, UVP, RCD, SPD	
Output Protection	OCP, OVP, LVP, OTP, IMD	
Internal Protection	OTP, AC contactor detection, DC contactor detection, Fuse detection	
Load Management	Via OCPP 1.6 JSON	
User Interface & Control	Display	7-inch LCD
	Buttons	Right Button: Select the charging connector Left Button: Home/Stop charging
	User Authentication	RFID Support ISO 14443A/B, ISO 15693, FeliCa Lite-S (RCS966), OCPP, 2D barcode, APP, Mobile Payment
	Backend Support	OCPP 1.6 JSON
Environmental Conditions	Operation Temperature	-30 °C~50 °C (-22 °F to 122 °F), power derating from 50 °C (122 °F) and above
	Storage Temperature	-40 °C to 70 °C (-40 °F to 158 °F)
	Relative Humidity	5%~95% RH, non-condensing
	Altitude	≤ 2000 m (6560 feet)



Regulations	Safety	UL2231, UL2202
	EMI/EMC	UL2202
	Charging Interface	CHAdeMO Ver 1.2 CCS DIN 70121
Mechanical Specifications	Dimensions (W x D x H mm)	800 x 650 x 1900 mm (32 x 26 x 75 in)
	Weight (typ.)	< 500 kg (1102 lbs), with two charging guns
	DC Charging Connector	CCS1, CHAdeMO
	Cooling	Fan Cooling
	NEMA enclosures(NEMA)	NEMA 3R
	Anti-vandalism	IK10, (LCD & RFID cover not included)

## 2.2 DC180P Version Description

The DC180P series are available in different versions depending on the charging connectors, the table below shows the available combinations. The corresponding position of charging connectors is indicated from left to right on the front of the charger.

Version (Model ID)	Left DC Connector	Right DC Connector
DC180P CCS1 CCS1	CCS1	CCS1
DC180P CCS1 CHAdeMO	CHAdeMO	CCS1

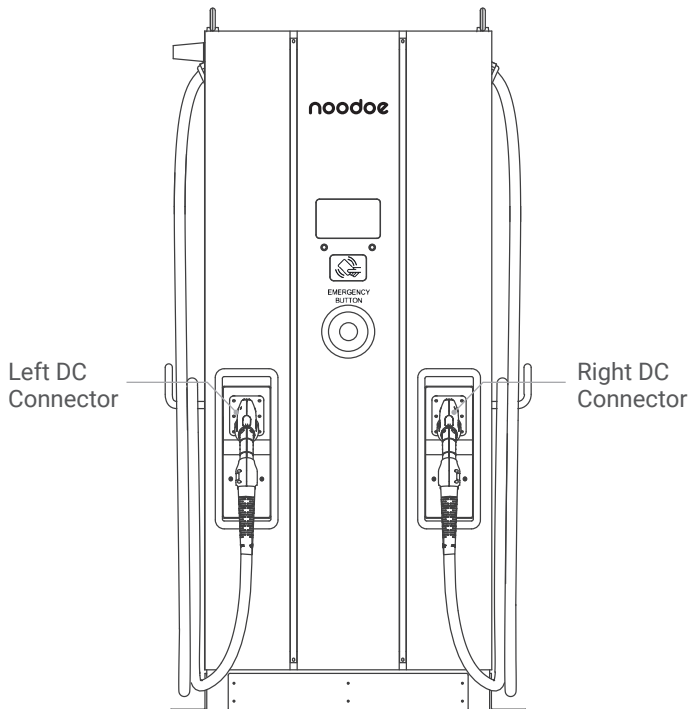

## 2.3 LED Indication and Operation Status

Status	LED	Left Indicator	Right Indicator
Standby		Green	Green
Fault		Red	Red
Charging		Blue	Blue

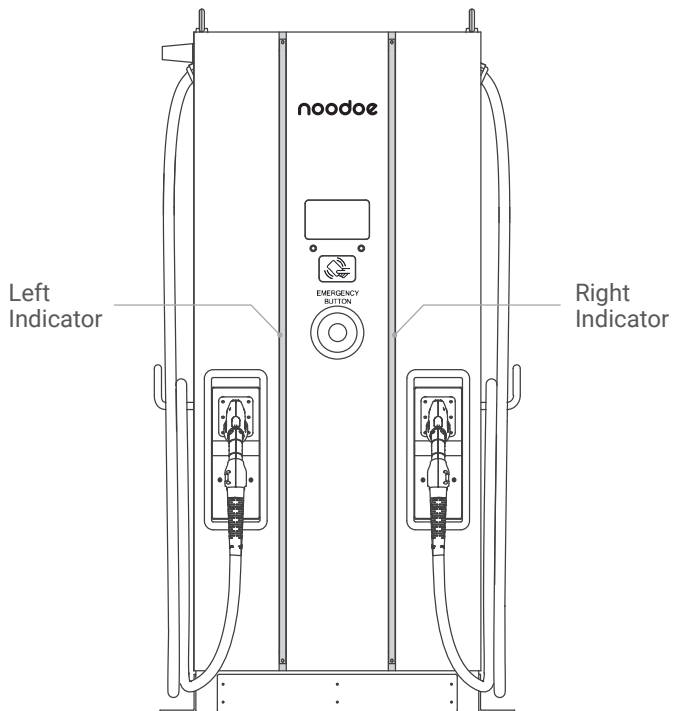

## 2.4 Dimensions

Main Size of the Charger: (unit: mm)

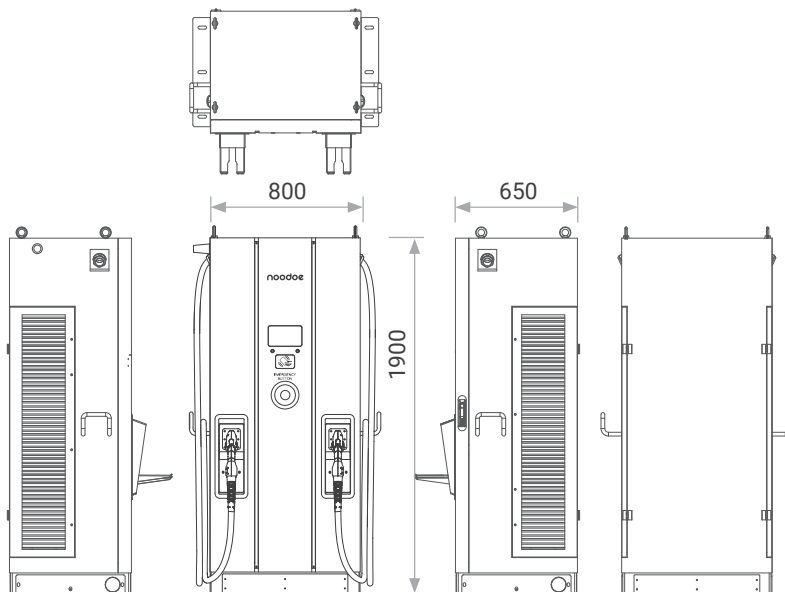

## 2.5 Direction of Cooling Airflow

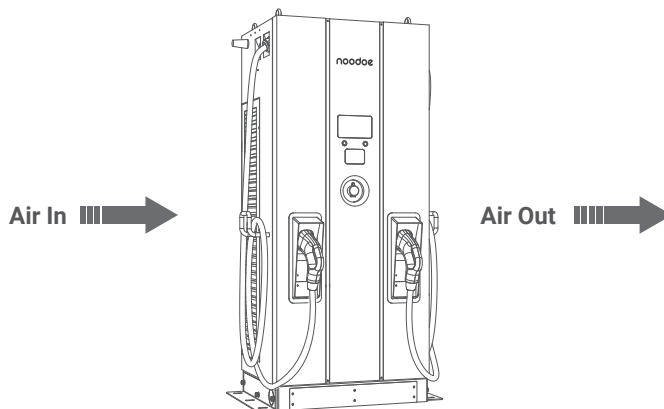

# 3. Installation Instruction

## 3.1 Before Installation

- Read all the instructions before using and installing this product.
- Do not use this product if the power cable or the charging cable is damaged.
- Do not use this product if the enclosure or the charging connector is broken or open or if there is any damage.
- Do not insert any tool, material, finger or other body part into the charging connector or the EV connector.



**WARNING:** The product should be installed only by a licensed contractor and/or a licensed technician in accordance with all building codes, electrical codes, and safety standards.



**WARNING:** The product should be inspected by a qualified installer prior to initial use. Under no circumstances will complying with the information in this manual relieve the user of his/her responsibilities to comply with all applicable codes and safety standards.

- Power feed must be 3-phase Wye configuration with TN(-S)/IT/TT grounding systems.
- In the installation of TN(-S) system: the neutral (N) and the PE of the power distribution are directly connected to the earth. The PE of the charger equipment is directly connected to the PE of power distribution and have separate conductors for PE and neutral (N).
- In the installation of IT system: the neutral of the power distribution system is isolated from the earth. The PE of the charger equipment is isolated to the PE of power distribution to the earth.
- In the installation of TT system: the neutral (N) and the PE of the power distribution are directly connected to the earth. The PE of the charger equipment is isolated to the PE of power distribution to the earth.
- The capacity of the power supply should be higher than 194 kVA in order to function correctly.
- The product should be installed in an open-air area and all product air vents must have at least 30 cm (12 in) of clearance.
- Sufficient space is necessary for product installation and maintenance; please keep not less than 107 cm (42 in) clearance distance from all around the product.



### **NOTICE**

It is recommended to conduct Wi-Fi and 4G signal strength during charger installation. The RSSI (Received Signal Strength Indication) value is considered good when higher than -65 dBm. Poor connection quality might interrupt charging process or data transaction.

## **3.1.1 Contractor Safety guide**

### **Introduction**

- Create a safe work environment for everyone - participants, installation and demolition crews, contractors and subcontractors.
- Ultimately, it is the responsibility of contractors to ensure the safety and safe work practices of their employees and subcontractors who may be working at the site on their behalf.
- This guide provides a simple reference guide with basic rules for implementation. It does not outline every single safety standard: it is designed to be a supplement to participants, contractors and subcontractors.
- Contractors, subcontractors and employees should cooperate with their employers and other persons in complying with safety regulations and instructions.

### **In particular, employees should:**

1. Obtain the qualified authorization of the responsible unit in the construction area.
2. Work safely.
3. Not do anything to endanger themselves or other persons.
4. Use personal protective equipment as required and take reasonable care of it when it is not in use.
5. Report unsafe activities immediately to supervisors or the responsible person in control of the workplace.
6. Report all accidents and dangerous occurrences to the supervisor immediately after they happen.

## 1. Requirements for Workplace Conditions

- Set up suitable fencing to isolate the construction area.
- Close and secure all entrances when the site is unattended.
- Hang warning notices that show the following information: warning icon and phone number of person in charge.
- Install sufficient lighting fixtures.



## 2. Cleaning Up

- Keep work areas (including accessways) free from debris and obstructions.
- Keep ground surfaces tidy and flat, to avoid people tripping or being hurt by tools or other objects.
- Stack and store equipment and materials in a tidy and stable manner.
- Regularly clean up and dispose of waste.
- Remove all surplus materials and equipment after completion of work.



## 3. Fire Hazards

- Beware of flammable materials and goods. Keep them away from work areas.



#### 4. Protection against High Temperatures on the Worksite

- Erect a sunshade or shed to shelter workers from the heat and sun.
- Set up cooling equipment, such as exhaust fans.
- Make water dispensers available.
- Provide suitable protective clothing such as hats, sunglasses and long-sleeve shirts to protect workers from heat stroke and UV rays.



#### 5. Inclement Weather

- Secure all scaffoldings, temporary structures, equipment, and loose materials.
- Check and implement SOP to ensure disconnection of gas supplies, electrical circuits and equipment.
- Inspect worksites to ensure protection against ingress of water or dust.
- Inspect the drainage system for blockages and remove if found.
- Stop all outdoor work except for emergency work.



#### 6. Ladders

- Only use ladders that meet local safety regulations.
- Do not use wooden ladders.
- When working at height, it is recommended to use platforms instead of ladders.
- If using a platform is not practicable, a supervisor should assess the potential risk and provide safety protection equipment for workers.





- Use non-conductive ladders made of glass-fiber or reinforced plastic when carrying out electrical work.
- Assign assistants to provide support when working on ladders.
- Check all ladders for broken rungs or other defects before use and periodically.
- Fully open stepladders when in use.
- Do not stand on the top two rungs of a ladder.
- Do not overreach when working on a ladder.
- Beware of overload restrictions.

### Common Standards for Ladders

Country	Standards
British	BS1129, BS2037, EN131, EATS13/1
USA	ANSI A 14.1, ANSI A 14.2, ANSI A 14.5
Australia New Zealand	AS 1892.2-1922, AS/NZS1892.1, AS/NZS 1892.3
Canada	CSA Z11 M81

## 7. Working at Height

- Avoid working at height by using alternative tools and methods as far as practicable.
- It is strongly recommended to build suitable scaffolding or work platforms.
- Provide fall arrest systems for workers if it is impracticable to use working platforms.
- Secure all materials and tools to prevent them from falling from height.

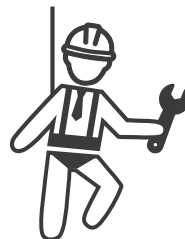

## 8. Lifting Operations

- Have lifting gear and apparatus regularly inspected and tested by qualified persons.
- Isolate and cordon off lifting areas to keep out non-construction personnel.
- Ensure that lifting routes do not cross buildings or people, and avoid collision with objects.
- Do not exceed safe working load limits.



## 9. For On-site Workers

- Plan all work.
- Turn off power (work with live parts de-energized whenever possible).
- LOTO (Lock Out, Tag Out).
- Live electrical work permit (input terminals with HV after door open).
- Use personal protective equipment (PPE).
- Ensure safe workplace conditions and space.
- Adhere to other occupational health, safety and security codes, such as those published by OSHA.



## 10. Reference standards

### Adhere to the following codes:

- NFPA-70E -2021 Sec 110.3 (Electrical Safety in the Workplace)
- NFPA-70E -2021 Sec 130.4 (Shock Risk Assessment)
- NFPA-70E -2021 Sec 130.5 (Arc Flash Risk Assessment)



## 3.2 Grounding and Safety Requirement

- The product must be connected to a grounded, metal, permanent wiring system. Connections shall comply with all applicable electrical codes. The ground resistance is recommended to be less than 10  $\Omega$ .
- Ensure no power is connected at all times when installing, servicing, or maintaining the charger.
- Use the appropriate protection when connecting to the main power distribution network.
- Use appropriate tools for each task.



### **CAUTION**

The disconnect switch for each ungrounded conductor of AC input shall be provided by the installation contractor or technician.



### **CAUTION**

A cord extension set or second cable assembly shall not be used in addition to the cable assembly for connection of the EV to the EVSE.

### 3.2.1 Service Wiring

- **Ground Connection**

Always connect the Neutral at the service to Earth Ground. If ground is not provided by the electrical service then a grounding stake must be installed nearby. The grounding stake must be connected to the ground bar in the main breaker panel and Neutral connected to Ground at that point.

- **480 Vac 3-Phase (Line to Line)**



**CAUTION**

This is the feed from Wye-connection power grid. The Standalone DC Fast Charger can connect to L1, L2 or L3, and Neutral. Earth ground must be connected to neutral at only one point, usually at the breaker panel.

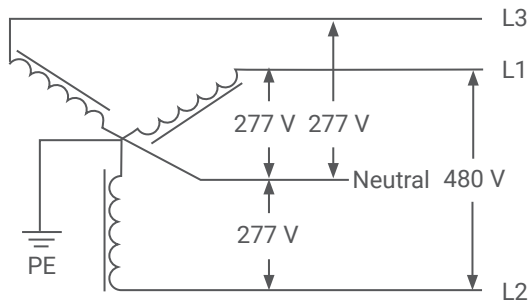

480 V 3-Phase Wiring Connection



**DANGERS**

Beware of High Voltage



**WARNING**

Earth Connection is Essential

# 3.3 Safe Shutdown

## 1. Introduction:

To prepare a control board which includes door sensor sensing function and tilt sensor, also dry contact points for extending wiring to upstream circuit breaker in order to cut off power immediately when sensors triggered. This board also has self-test button which uses to verify if it functions properly no matter in production line or in installation site or during regular maintenance service.

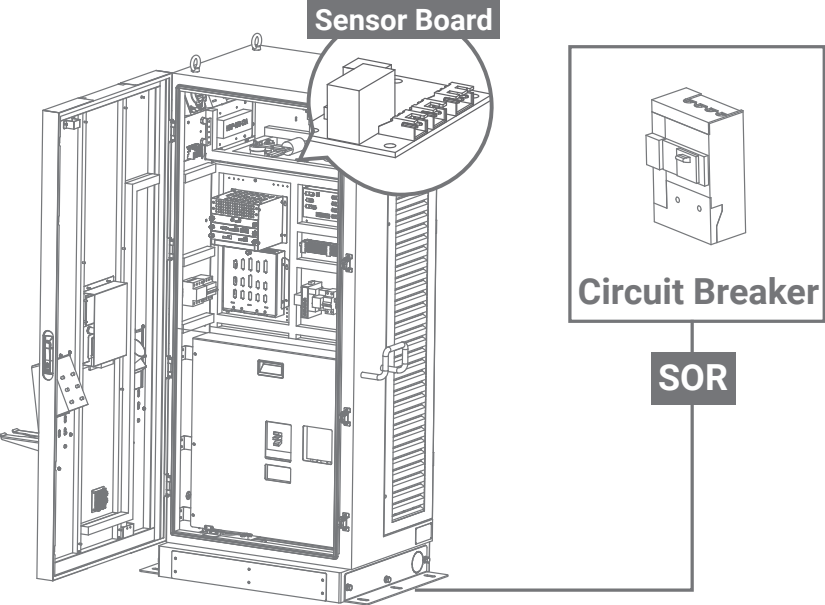

## 2. Sensor board:

- When either the door or tilt sensor has been triggered, power will be cut off at the upstream circuit breaker.

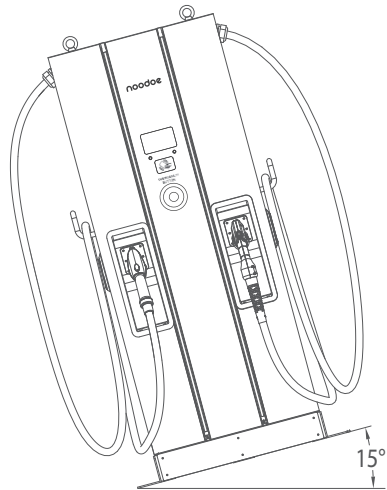

- When the upstream circuit breaker has been cut off, the charger will shut down entirely. Once the charger is offline, it cannot be recovered remotely and will need to be serviced on site.

### 3.4 Unpack the charger

- The product is a direct current (DC) charger, the packing design passed the packaging simulation test, if the packaging has been damaged due to over-turning, falling or experiencing an external impact during transportation, it may cause the product damage or defects. If there is any serious damage to the packaging upon receipt of the product, please notify Noodoe about your findings.
- Receiving the DC180P charger: The product is delivered by a transport company to a warehouse or specified location where it will be handed over. Transporting the DC180P charger to its final location (last mile service) is not a standard part of included in the order.
- NOTICE: The delivery truck unloads the pallet carrying the DC180P charger. The movement of the DC180P charger to its final location is the responsibility of the customer/contractor.



- Checking the TiltWatch PLUS sensors: If the TiltWatch PLUS indicator is tilted over 80°.
  1. Do not refuse the delivery/receipt.
  2. Make a note on the delivery receipt and inspect the cabinet for damage.
  3. If damage is discovered, leave the cabinet in its original packaging and request immediate inspection from the carrier within 3 days of delivery.
  4. Contact Noodoe by email ([techsupport@noodoe.com](mailto:techsupport@noodoe.com)) to notify us of your findings.



**WARNING**

The charger weight might be 470 kg. The charger with packaging might be 570 kg. Be careful during the unpacking process.

**STEP 1.**

Remove the surrounding boards.

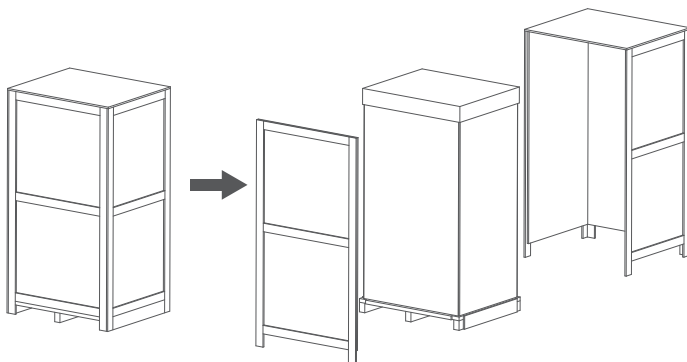

**STEP 2.**

Remove the carton and packing cushion and film.

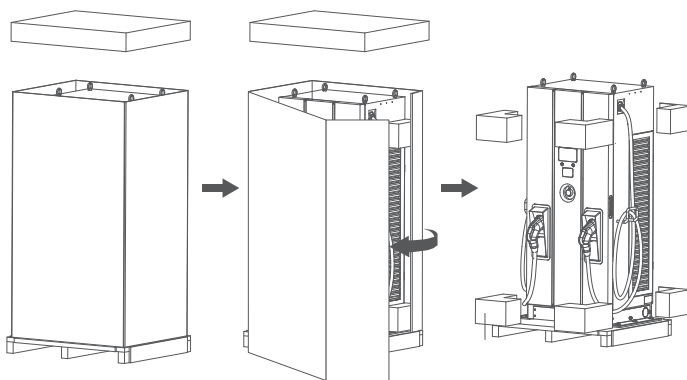



### STEP 3.

Remove these 6 fixing M12 screws.

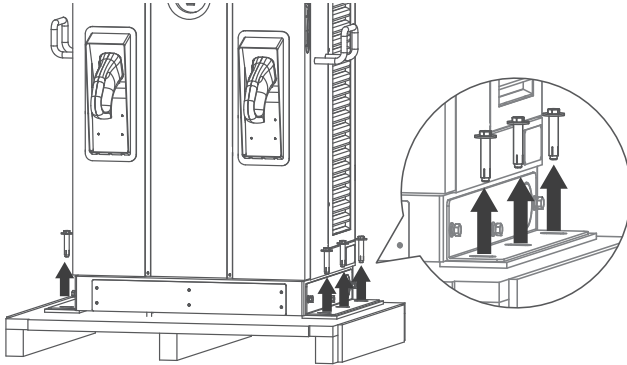

### STEP 4.

To use lifting eye bolts to move the EVSE, please apply 6 mm (1/4 in) diameter steel wire rope to the four eye bolts as following picture.

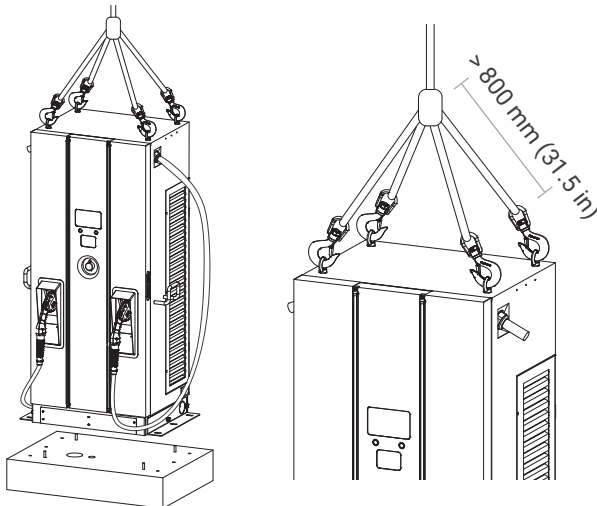

## 3.5 Recommended Tools for Installation and Inspection

### 3.5.1 Recommended Tools for Installation

Type	Description
Philips Screwdriver	No. 2 and 3
Shifting Wrench	
Socket Screwdriver	No. 8 and 10 and 17 and 19
Electrical Tape	Black/15 mm (0.6 in) width
AC Input Cable	185 mm <sup>2</sup> (365 kcmil) at least cable x 5 (L1, L2, L3, N, PE)
Ring Terminal	1. Ring terminal for L1, L2, L3, N (inner diameter: 10.5 mm (0.41 in), outer diameter: 38.5 mm (1.51 in)) 2. Ring terminal for PE (inner diameter: 10.5 mm (0.41 in), outer diameter: 38.5 mm (1.51 in))
Crimping Pliers for Ring Terminal	Hexagonal
Wire Stripper	
Wire Cutters	
Crane / Forklift	< 500 kgW (1102 lbs)

### 3.5.2 Recommended Tools for Inspection & Commissioning

Type	Description
EV or EV Simulator	Meet CHAdeMO / CCS standard
Multiple Meter	1000 V
Current Probe	400 Amp
Authorized RFID Card	
Unauthorized RFID Card	
Door Key	
Needle-Nose Plier	
Laptop or PC & CAT6 Cable	For charger configuration
Wi-Fi /4G Signal Quality Checker	Recommended

## 3.6 Installation Procedure

### 3.6.1 Build Concrete Base

#### STEP 1.

1. Build 1090 x 750 x 200 mm (42.91 x 29.53 x 7.87 in) concrete base on the level to charger stand in advance.
2. Implant AC input cable conduit less than  $\Phi 102$  mm (eg. 3" PVC conduit), and SFTP Ethernet cable conduit less than  $\Phi 34$  mm (eg. 1" PVC conduit).
3. Implant 4 M12 screw sticks protruding 40 mm (1.57 in) out the concrete base to affix the charger to. The positioning of these 4 M12 screws should be within  $\pm 2$  mm (0.08 in) in short, and  $\pm 8$  mm (0.32 in) in long axis, according to screw holes of charger.
4. To fit this positioning requirement, a steel plate fixture is suggested. Please create the fixture according to the following drawing or order this fixture from your vendor.
5. The other way to affix the charger to the concrete base is to install 2 L-bracket accessories outside of the charger and drill the screw holes ( $\Phi 16$  mm (0.63 in)) into the cement base as illustrated below.

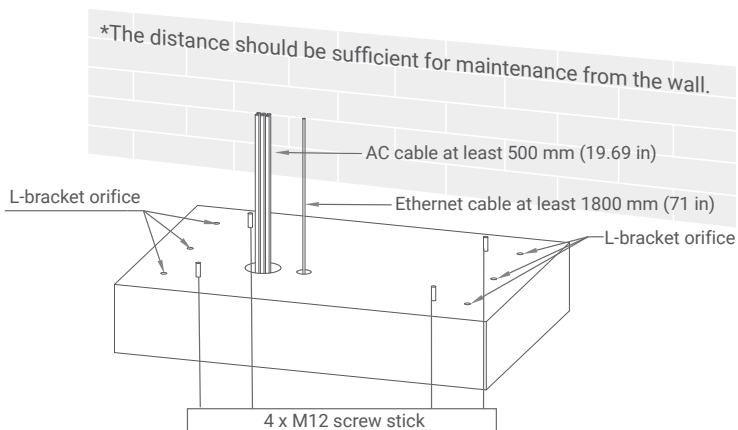

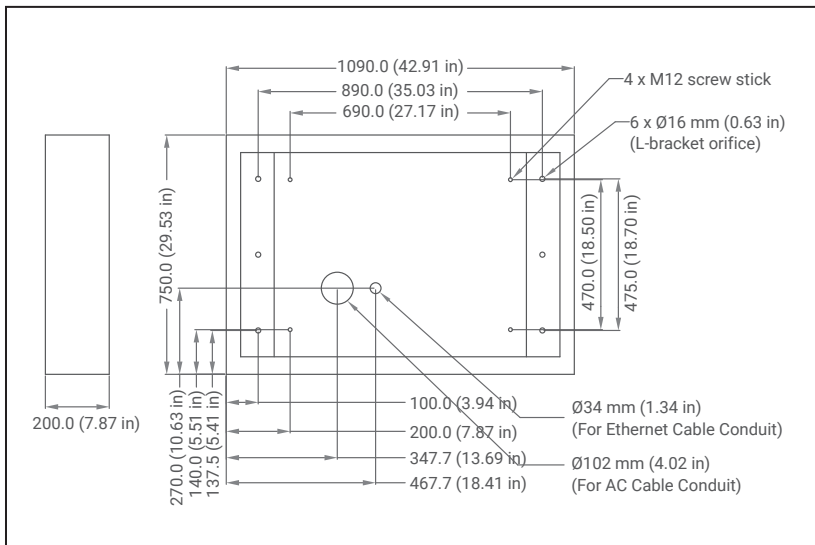

## STEP 2.

1. Extend 3 phase 5 wires AC input cable from conduit of the concrete base. At least 500 mm (19.96 in) of AC cable should be exposed, and these 5 wires should be with ring terminals ...ring terminals. L1, L2, L3&N: Inner diameter: 10.5 mm (0.41 in), outer diameter: 38.5 mm (1.51 in) & PE: Inner diameter: 10.5 mm (0.41 in), outer diameter: 38.5mm (1.51 in).
2. The conductor cross sectional area of input power wires should not be less than 95 mm<sup>2</sup> (212 kcmil). If the internet connection is via Ethernet, a 1800 mm (71 in) Ethernet cable is necessary to install via the conduit to the charger.

### 3.6.2 Two Methods of Fixing DC180P Charger

#### METHOD 1.

Lift the charger onto the concrete base, and pull the input cable through the bottom hole of charger. Fasten 8 M12 screw nuts and 4 M12 washers on 4 M12 screw in the concrete base (2 nuts for each screw) to secure the chargers. Then fix the base cover (in the accessory pack) to the charger base.

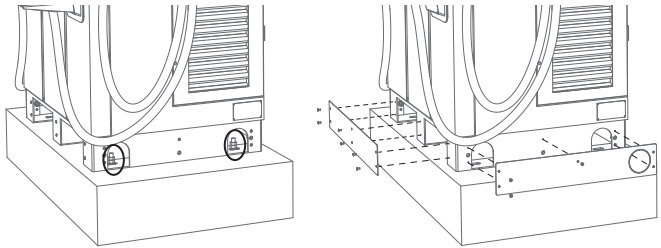

#### METHOD 2.

If L-brackets are used to affix charger, secure L-brackets on the cement base by 6 M12 expansion bolts.

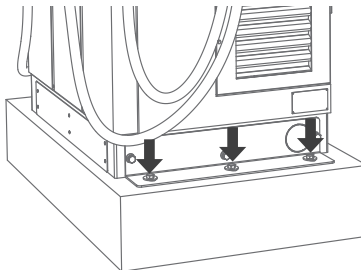

### 3.6.3 Installing Cables

#### STEP 1.

Open the front door and disassemble the protection cover for wiring:

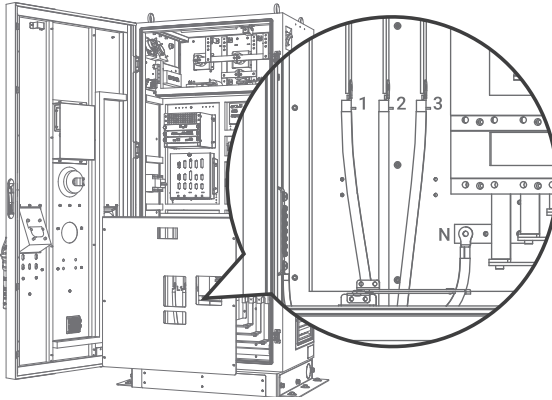

#### STEP 2.

Connect L1, L2, L3 and N of AC power to 4P terminal. Fasten each wire with proper screw and torque number—180 Kgf.cm/5-15 secs. Connect the PE wire (green and yellow) to Grounding position of Charger and torque number—220 Kgf.cm. Keep proper length of each wire, then fasten cable grand.

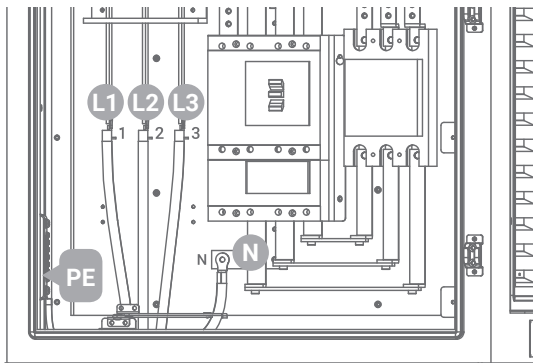

### STEP 3.

Pull AC power cables to power distribution box, and then connect the Protective Earth wire (Green/Yellow) to ground point of power distribution box. Neutral should be shortened to ground point to meet TN(-S) grounding system. Ethernet cable should be connected to charger RJ45 port. (refer to pic. in section 4.1)

### STEP 4.

Wiring installation of L1, L2 and L3 of 3 Line wires and Neutral wire to external breaker. Recommended breaker spec: Max. input current should not be not less than 300 A, B curve type, Max. residual leakage current (RCD) shall be 30 mA .



A 400 A NFB with 30 mA RCD-Type A is recommended.

### STEP 5.

Do Inspection per section 3.6.1 to 3.6.3 .

Turn on the power source and be ready for operational testing. The power supply of the Standalone DC Fast Charger will be enabled and automatically drive the information screen. The information screen will turn to charging solution screen within 30 seconds.



Not following installation instructions will cause charger damage.

### STEP 6.

Use adaptive flame retardants and electrical insulated foaming agent and far from conductive live parts at least 12 mm or other method to seal the cable entry hole to assure the NEMA 3R grade of the charger, and prevent insects enter the cabinet.

## 3.7 Installation Inspection & Commissioning

### 3.7.1 Environmental Check

Item	Status	Remark
Ambient Temperature		
Ambient Humidity		
Sunshade		Recommended but not required.
Rain Canopy		Recommended for better charging experience and maintenance on rainy day.
Air Circulation / Drafty		
Dust Level		
Anti-Vandalism Measures		

### 3.7.2 External Infrastructure Readiness & Check

Item	Status	Remark
Input Wirings & Terminals		Type/Length/ Cross Section
Key & Lock of Cabinet Door		
Fixing Screws		Type/No.
No Fuse Breaker (NFB)		Notice: Current rating of NFB shall be higher than 300 Amp
Residual Current Device (RCD)		Maximum RCD residual current shall not exceed 30 mA
Input Electricity Capacity		
Input Electricity Configuration		Wye
Grounding Resistance		<10 Ω
Grounding System		
Input Voltage & Frequency		
Network Connection & Quality		Wi-Fi, 4G > -65 dBm



### 3.7.3 EVSE Check – Static (Non-Powered)

Item	Status	Remark
Outlook		
Labeling & Warning Signs		
Package (Accessory) List		
Robustness of Input Wirings & Connection		Refer to section 7.1 Screw torque requirement table

### 3.7.4 EVSE Check - Power On

Item	Status	Remark
Screen On		
Acoustic Noise		
Screen Display & Function		
Time Display Correctly		
Network Connection Quality		
Cooling Fans Operation & Noise		
Led Status Indication		
EVSE Setting		
Function of Engineer Mode		
Version of H.W. & F.W.		
Remote Control & Monitoring		
Backend Server Connection		
Network Connection & Quality		Wi-Fi, 4G > -65 dBm

### 3.7.5 EVSE Check - Charging

Item	Status	Remark
User Authorization –RFID		
User Authorization –QR Code		
User Authorization –Others		
Waiting Time of Connection Check		
Reading of Each Display Item		
Full Charge Test		
Function of Electronic Lock		
Reading of Engineer Mode		
Airflow & Noise of Cooling Fan		
Charging Record (log) Upload		
Remote Control & Monitoring		

### 3.7.6 EVSE Check –System Power Button

Item	Status	Remark
Emergency Stop Button & Recovery		

## 4. Network Setting

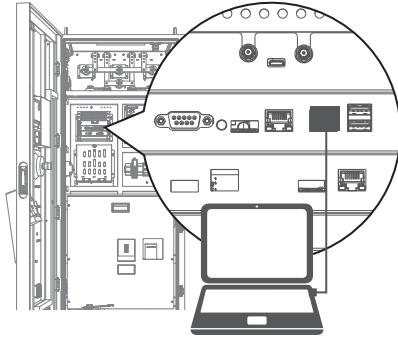

### 4.1 Wi-Fi Network Setting

- Laptop with RJ45 interface.
- Connect RJ45 cable from Laptop to charger's RJ45 port.
- Setup parameters in the Web service.

Use the following IP address:

IP address:

Subnet mask:

Default gateway:

#### Step 1.

Before opening the web browser, please enter network setting and set your IPV4 static IP to 192.168.1.1 in your PC.

#### Step 2.

Open web service browser, and type the IP address of the charger "192.168.1.10" into the URL bar to access the charger's web page.

- Account: admin
- Password: 1231231238

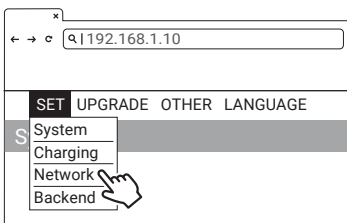
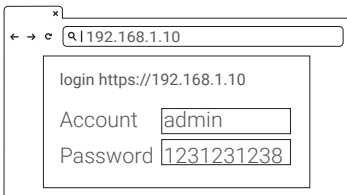

#### Step 3.

SET -> Network

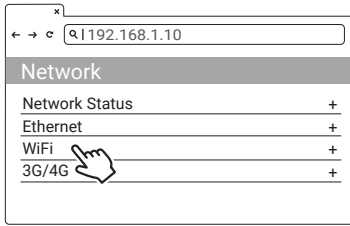

#### Step 4.

Select Wi-Fi Module

Select Wi-Fi modes and fill in SSID and Password according to your application.

If not required, keep default settings.

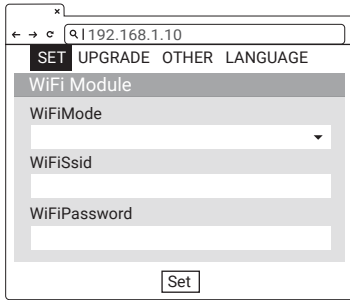

Wi-Fi Setting	Description
Wifi Ssid	Service Set Identifier, SSID
Wifi Password	Password to access to Wi-Fi
Wifi Dhcp Server	DHCP server of Wi-Fi
Wifi Dhcp Client	DHCP client of Wi-Fi
WifiIpAddress	Wi-Fi IP address
WifiSubmask Address	Wi-Fi submask address
WifiGateway Address	Wi-Fi gateway address



#### WARNING:

Due to the different environmental conditions, it is recommended to conduct Wi-Fi and 4G module network signal tests before installation. The RSSI (Received Signal Strength Indication) value should be higher than -65 dBm. If it is lower than this value, there is a risk of abnormal Wi-Fi or 4G connection quality or disconnection due to the influence of external environmental interference.

## 4.2 3G/4G Setting

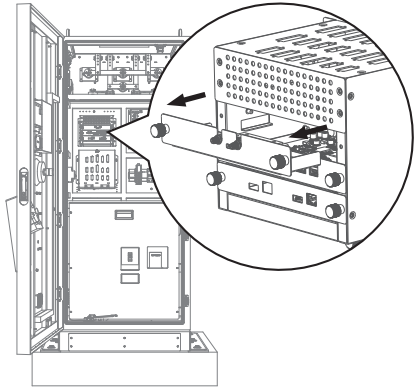

### 4.2.1 SIM Card Installation

#### Step 1.

Pull out the first tray from the CSU box, and you will see the 4G/Wi-Fi module inside the cabinet.

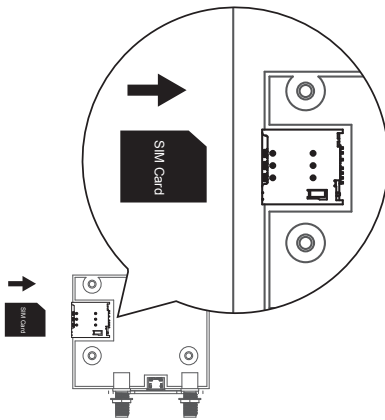

#### Step 2.

Insert 3G/4G Micro SIM Card into the tray, ensuring that the gold contacts are facing down and the notch is located in the upper right corner. Note that the tray might be damaged if SIM card is inserted in the wrong direction.

## 4.2.2 Setting and Enable 3G/4G Module

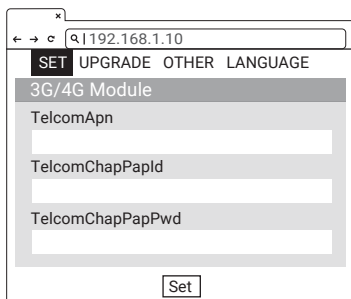
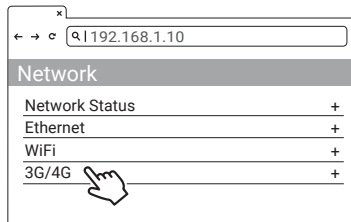
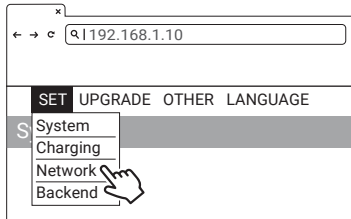
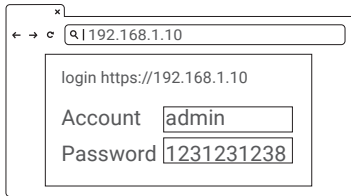

### Step 1

- Please contact your SIM provider to get the APN, PPP ID and password.  
\* Note: PPP ID and password options depend on your SIM provider.
- Open the web page for the charger and sign-in.

### Step 2

SET -> Network.

### Step 3

- Network -> 3G/4G Module to fill corresponding information into TelcomApn, TelcomChapPapId and TelcomChapPapPwd.
- Press "Set" to save all information. 3G/4G will be activated in few minutes.

TelcomApn	APN Setting
TelcomChapPapId	Login ID authentication
TelcomChapPapPwd	Login password authentication
TelcomIpAddress	IP address

## 4.3 Time setting

### Automatic setting :

The time will be adjusted automatically when the charger connects to the internet.

Time server :

- time.windows.com
- cn.ntp.org.cn
- tock.stdtime.gov.tw

Note: Firewall and network environment may influence the time server connection.

### Manual setting :

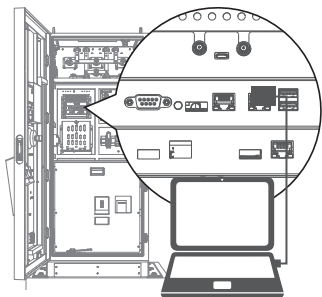

#### Step 1.

- Laptop with RJ45 interface.
- Connect RJ45 cable from the laptop to charger's RJ45 port.
- Setup parameters in the Web service.

Use the following IP address:

IP address:

Subnet mask:

Default gateway:

#### Step 2.

Before opening the web browser, please enter network setting to set your IPV4 static IP to 192.168.1.1 in your PC.

Browser window showing login page for https://192.168.1.10

Account:

Password:

#### Step 3.

Open web service browser, and type the IP address of the charger "192.168.1.10" into the URL bar to access the web page for the charger.

- Account: admin
- Password: 1231231238

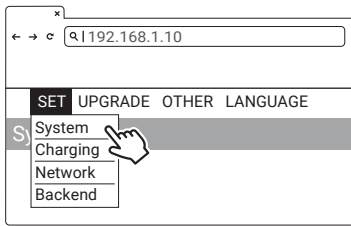

**Step 4.**  
SET -> System.

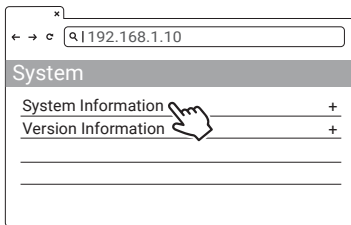

**Step 5.**  
Click "System information".

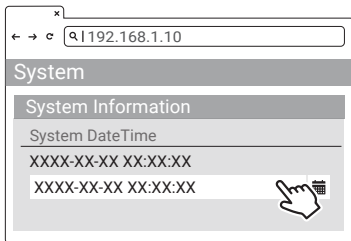

**Step 6.**  
Click system date time.  
Click the calendar button on the right to set the current time.

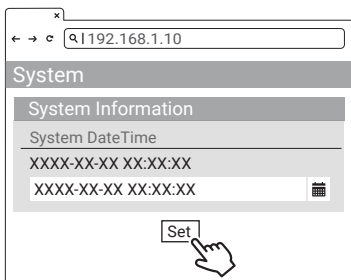

**Step 7.**  
After the settings are complete, click SET and wait until the setting completion window appears.



# 5. Activation Instructions

## 5.1 Activation Overview



Prior to activation, make sure to collect the necessary information for the site and charging station owner. Noodoe EV Exceed DC Series chargers have two visible Station ID QR codes on them.

- Scan either of the codes to begin the activation process through our web portal.
  1. Enter the project code provided by Noodoe EV or your Charge Point Operator. If you do not have one, create a site. (see 5.3)
  2. Confirm or add station ID. (see 5.4)
  3. Upload photos of the charging station. (see 5.5)

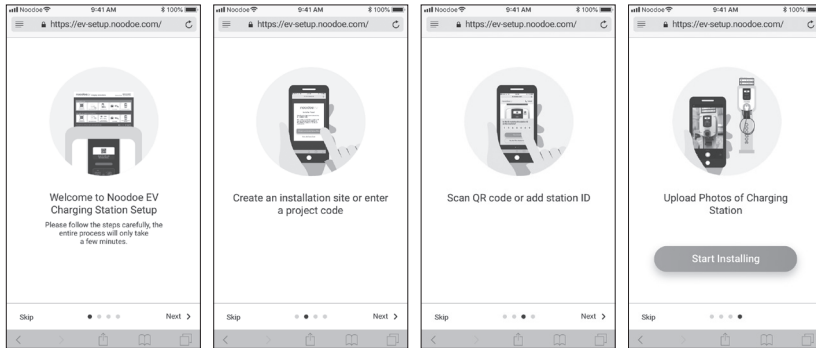

## 5.2 Prior to Activation

Before starting, collect the following information:

- Site Details
  1. Address
  2. Phone number
- Charging Station Owner's Credentials
  1. Full name
  2. Email address
  3. Phone number

## 5.3 Creating a Site

If you have a project code provided either by Noodoe EV or your charge point operator, use that to begin the process. If there is no code, choose “Create an Installation Site” to begin activation.

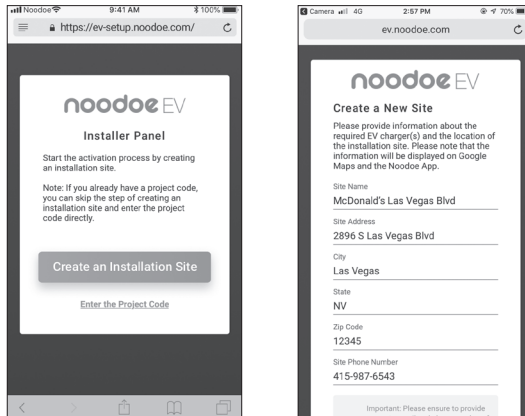

### Site & Owners Information

- To finalize site creation, you will need a few pieces of information. Make sure you have all of this information before moving ahead with the activation procedure.
- Site Information:
  1. Site name
  2. Site address
  3. Site phone number
- Station Owner's Information
  1. Charging Station Owner's name
  2. Charging Station Owner's email address
  3. Charging Station Owner's phone number
- Installer information
- NOTE: This site information will be used on a charger location map, so it must be accurate. Additionally, the Charging Station Owner of the site will be responsible for managing the chargers, receiving payments made through them, and paying the subscription fees for Noodoe EV OS.

## 5.4 Adding Charging Stations

Make sure the stations are powered up and the site has been created in the setup program.

- Add each station one by one.
  1. Add stations by scanning their QR codes OR
  2. Add stations using their Station IDs

## 5.5 Taking Charging Station Photos

Photos are important for helping EV drivers find your charging stations. Take a photo of each station to be used in Google Maps and in the Noodoe App.

Photo Suggestions:

- Take closeups of each charger (with the QR code visible).
- Include pictures taken from a distance so drivers can see the parking environment.
- State parking instructions where necessary or useful.

## 6. Operation Process

### 6.1 Operating Sequence

- System Initialization
- User Authorization
- Plug in DC Charging Connector
- Preparing for Charging
- Charging
- Charging Terminated
- Status Messages

### 6.2 Operating Procedure

#### 6.2.1 System Initialization

- When the charger is powered on, the “Charging Station” Initializing page will appear.
- You will see the image below on the screen after the power is on and the system is initializing.
- The initialization process will take around 2 minutes, then the home page will appear.

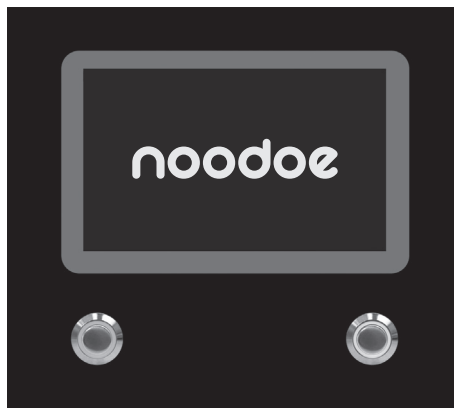

Initializing page



Unit and currency if billing function is enabled

- Ethernet Backend Status



Connection

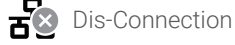

Dis-Connection

- Wi-Fi Status



Connection



Dis-Connection

- 3G/4G Status



Connection



Dis-Connection

- OCPP Backend Status



Connection



Dis-Connection

## 6.2.2 User Authorization

- After the system is initialized, the screen will stay on the Home page as illustrated below.
- Use your RFID card or mobile app to authorize the use of the EVSE.

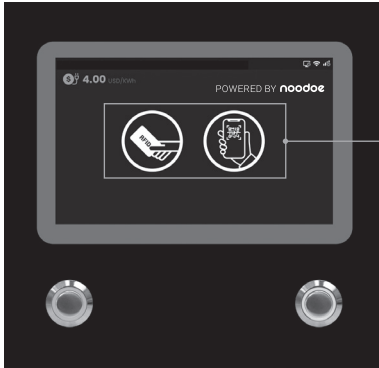

Home page

User authorization Method: RFID, QR code.

- Unauthorized method(s) will be darker on the screen if the method is disabled.



User authorizing



User authorized.



Authorization failed

## 6.2.3 Plug in Charging Connector

- After authorization, the screen will ask the user to plug the charging connector into the EV charging inlet as illustrated below.
- Take the charging connector from the charging cable holder and plug the connector into EV charging inlet. The charger will automatically detect the type of charging connector.
- It will normally take less than 10 seconds to start the process after completing the physical connection between the charging connector and the charging inlet. To terminate this session, please press the left button to return to the Home page.

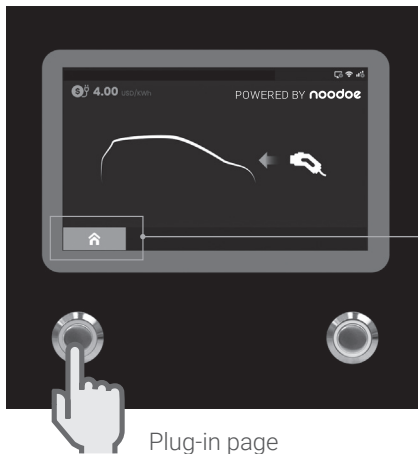

The screen will return to the home page and terminate this session if the left button is pressed.



The left connector will always have the charging priority when plug in 2 connectors simultaneously.



## 6.2.4 Prepare for Charging

- After authorization and plugging in, the charger will start communicating with the vehicle, and the screen will show the Preparing page as illustrated below.

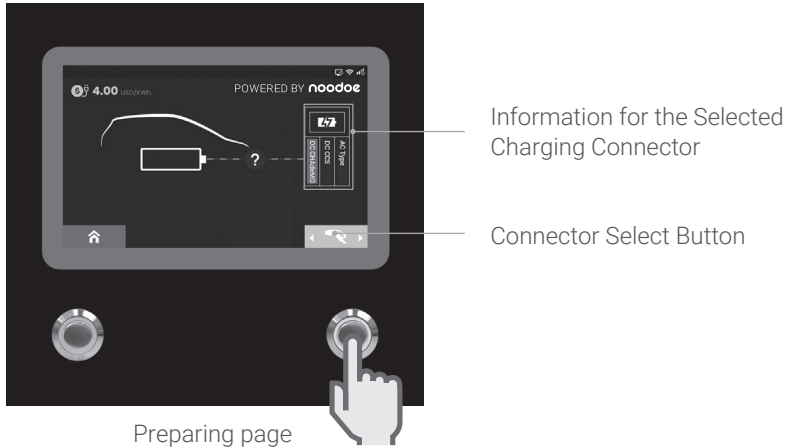

## 6.2.5 In Charging

- The screen will show the Charging page as illustrated below once the charger enters the ready-to-charge state.

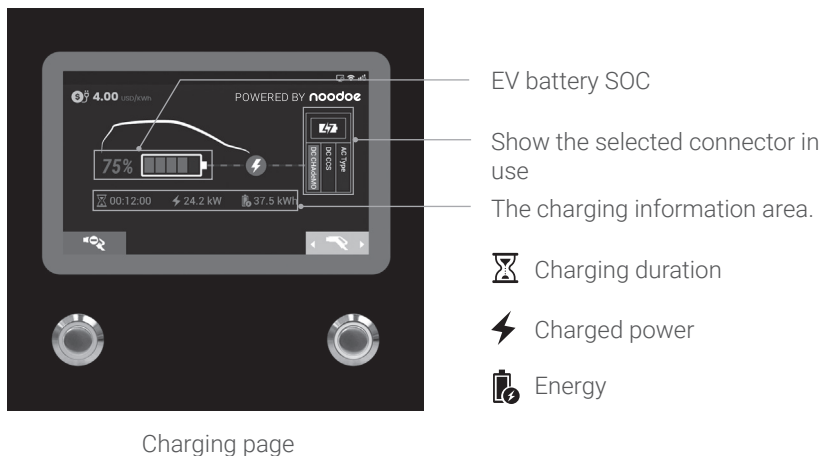

- To start charging, load the charging information. When the battery has been fully charged or reaches the limit of the setting it will stop charging automatically and go to the next process.

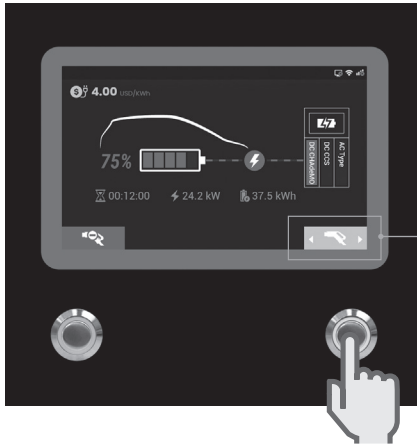

Press right button to select the charger connector that the user would like to stop.

- User also can tap the RFID to stop charging.

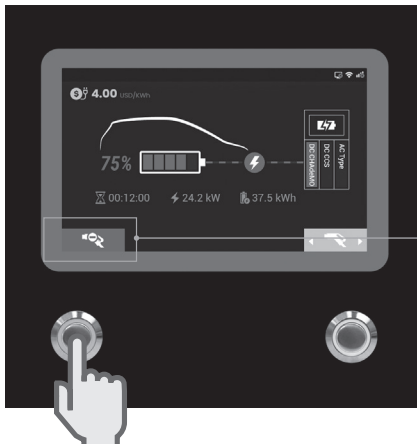

Tap RFID card or push stop button to stop



## 6.3 Troubleshooting

- Please follow the instructions in the table when errors occur during the charging process.
- Or contact the DC Quick Charger provider for further instructions.
- If an emergency occurs, push the Emergency Stop Button to stop charging immediately.

### 6.3.1 Troubleshooting Guide for End User

When charging fault occurs, user may eliminate fault status by following steps.

Conditions	Troubleshooting guide
Black screen	Please contact your dealer.
Stuck on boot or service screen	Please contact your dealer.
Card tapping or QR code scanning failed	<ol style="list-style-type: none"> <li>1. Invalid RFID card or insufficient balance.</li> <li>2. Card reader failure or other faults; please contact your dealer.</li> </ol>
Indication page returns from cable plugging to selection	<ol style="list-style-type: none"> <li>1. Please make sure the charging cable selection is correct.</li> <li>2. Please make sure the charging cable has been plugged in completely with a "clicking" sound, and the gun button cannot be pressed.</li> <li>3. Please check the charge port indicator or meter whether the charge function is failed.</li> <li>4. Please try again with other chargers. If the situation keeps the same, the EV perhaps unable to charge, please send the EV for service.</li> <li>5. Charging cable or control guide invalidated, please contact your dealer.</li> </ol>

Conditions	Troubleshooting guide
Indication page transfer from charging preparation to settlement directly	<ol style="list-style-type: none"> <li>1. Please unplug the charging cable and try again.</li> <li>2. Please check the EV charge port indicator or meter whether the target charging limit has been done or terminated before default charging time.</li> <li>3. Drive the EV away for few meters / feet and return, then try again.</li> <li>4. Please contact your dealer.</li> </ol>
Stuck on SOC 100% or 0% settlement page without charging	<ol style="list-style-type: none"> <li>1. Please check EV charge port indicator or meter, whether full charged, the target charging limit is done or stopped before default charging time.*</li> <li>2. Please unplug the charging cable and try again.</li> <li>3. Please contact your dealer.</li> </ol>
Charging complete but the charger did not release EV	<ol style="list-style-type: none"> <li>1. Please unlock the EV, press the button of HV charging port cover, and try to unplug again.*</li> <li>2. Turn the startup switch on and off, then try to unplug again.</li> <li>3. Lock the EV doors and release, then try to unplug again.</li> <li>4. Turn the EV air conditioner off, then try to unplug again.</li> <li>5. Please release by EV manual unlock switch.</li> <li>6. If there is no manual unlock, please turn off or reset the charger.</li> <li>7. Contact your EV company or dealer.</li> </ol>

## 6.3.2 Troubleshooting - No Status Code

Conditions	Troubleshooting guide
Black screen	<ol style="list-style-type: none"> <li>1. Incorrect input power or connection fault, please supply power correctly and reset the power.</li> <li>2. Charger auxiliary power, display, or other faults. Please contact your dealer.</li> </ol>
Stuck on boot or service screen	<ol style="list-style-type: none"> <li>1. System is in update or self-check procedure, please wait.</li> <li>2. Other faults of charger, please reset the power or restart the charger.</li> <li>3. Please contact your dealer.</li> </ol>
Card tapping or QR code scanning failed	<ol style="list-style-type: none"> <li>1. Invalid RFID card or insufficient balance.</li> <li>2. Contact management staff to check internet connection between charger and Back-End server.</li> <li>3. Code scanning or Back-End authorization failed; please contact management staff.</li> <li>4. Card reader failure or other faults; please contact your dealer.</li> </ol>
Indication page returns from cable plugging to selection	<ol style="list-style-type: none"> <li>1. Please make sure the charging cable selection is correct.</li> <li>2. Please make sure the charging cable has been plugged in completely with a "clicking" sound, and the gun button cannot be pressed.</li> <li>3. Please check the charge port indicator or meter whether the charge function is failed.</li> <li>4. Please try again with other chargers. If the situation keeps the same, the EV perhaps unable to charge, please send the EV for service.</li> <li>5. Charger control guide failed. Please turn off and restart the charger.</li> <li>6. Charging cable or control guide invalidated, please contact your dealer.</li> </ol>

Conditions	Troubleshooting guide
Indication page transfer from charging preparation to settlement directly	<ol style="list-style-type: none"> <li>1. Please unplug the charging cable and try again.</li> <li>2. Please check the EV charge port indicator or meter whether the target charging limit has been done or terminated before default charging time. *</li> <li>3. Drive the EV away for few meters / feet and return, then try again.</li> <li>4. Charger handshaking failed, please reset, or turn off and restart the charger.</li> <li>5. Please contact your dealer.</li> </ol>
Stuck on SOC 100% or 0% settlement page without charging	<ol style="list-style-type: none"> <li>1. Please check EV charge port indicator or meter, whether full charged, the target charging limit is done or stopped before default charging time. *</li> <li>2. Please unplug the charging cable and try again.</li> <li>3. EV messages load failed. Please turn off and restart the charger.</li> <li>4. Please contact your dealer.</li> </ol>
Charging complete but the charger did not release EV	<ol style="list-style-type: none"> <li>1. Please unlock the EV, press the button of HV charging port cover, and try to unplug again. *</li> <li>2. Turn the startup switch on and off, then try to unplug again.</li> <li>3. Lock the EV doors and release, then try to unplug again.</li> <li>4. Turn the EV air conditioner off, then try to unplug again.</li> <li>5. Please release by EV manual unlock switch.</li> <li>6. If there is no manual unlock, please turn off or reset the charger.</li> <li>7. Contact your EV company or dealer.</li> </ol>

\*Each model of EV contains different charging condition and gun release method, please refer to your user manual.

### 6.3.3 (011-XXX) Troubleshooting - Error Code

011-XXX contains charger's parts or connection fault message; please unplug charging connector, turn power off, reconnect the issued part and then power on the unit. If same error code be displayed, then must be serviced by qualified technician. Please contact your dealer.

## 6.3.4 Troubleshooting - Warning Code Form

Status Code	iConditions	Troubleshooting methods
012200 ↓ 012214	Abnormal input voltage	<ol style="list-style-type: none"> <li>1. Charging can be enabled after electrical grid supply regularly.</li> <li>2. Please check the input power or turn off and restart the charger.</li> <li>3. Please contact your dealer.</li> </ol>
012223 ↓ 012232	Abnormal environment or devices temperature	<ol style="list-style-type: none"> <li>1. Keep the air flow inlet and outlet clear or remove heat sources, charging will be enabled after cooling down.</li> <li>2. Maloperation of over temperature protection or devices over temperature. Please contact your dealer.</li> </ol>
012241 ↓ 012244	External network disconnected	<ol style="list-style-type: none"> <li>1. Code scanning or app authorize application are unavailable for the moment, please change to RFID or other authorizations.</li> <li>2. Please contact network management</li> </ol>
012251	Emergency switch is pressed	<ol style="list-style-type: none"> <li>1. Please release the emergency switch by rotating, charging will be enabled after warning code is removed. (Meanwhile, if it shows service page, please rotating back the switch, turn off and restart the charger)</li> <li>2. Please contact your dealer or turn off and restart the charger.</li> </ol>
012252	The cabinet door has been opened	<ol style="list-style-type: none"> <li>1. Please close the cabinet door, charging will be enabled after warning code is removed.</li> <li>2. Door open sensor is shifted, please screw the sensor on the fixed position.</li> <li>3. Maloperation of door open sensor, please contact your dealer for further instruction.</li> </ol>
012304	Communication error between power and charging gun cabinet	<ol style="list-style-type: none"> <li>1. Please make sure the ethernet cable connection between cabinets to be reliable.</li> <li>2. If there is no green light solid on power cabinet, please reset it.</li> <li>3. Please contact your dealer for further instruction.</li> </ol>



### **6.3.5 (013-XXX) Troubleshooting - Message Code from Charger**

Code 013-XXX contains setup, maintenance, or reference hint messages. Generally there is no impact on charging. Continue charging as usual and contact your dealer.

### **6.3.6 (023-XXX) Troubleshooting - Message Code from EV**

023-XXX contains messages from the EV, it is a communication or charging procedure error. These errors occur because the charging cannot proceed or the cable cannot be unplugged. Please refer to your EV manual for charging setup or backup procedure, then eliminate fault status by following steps, or contact charger management staff.

1. Unplug the charging cable and wait for 5 or more seconds. Plug the charging cable in completely until there is an audible click and try the charging procedure again.
2. Unplug the charging cable, and attempt to charge using another charger.
3. Unplug the charging cable, drive the EV a few feet/meters away and return. Stop the EV, remove the key, and try again.
4. After unplugging the charging cable, check whether the EV's charging mode and time limit have been enabled.
5. If the charging terminates cannot be started and the EV meter or charging indicator shows abnormal status or error messages, please follow your EV user manual for troubleshooting.
6. After unplugging the charging cable, contact management staff to turn off restart the charger and try again.
7. If charging terminated but the charging cable cannot be unplugged, follow the EV user manual, press the release button (inside the EV or on the remote control or remote control) or manual unlock switch. If all of these methods are unavailable, contact management staff to turn off and restart the charger.

Status Code	Conditions	Description
23758	EV side feedback code procedure error	<ol style="list-style-type: none"> <li>1. Unplug the charging cable, release the EV side charging limit, and try again.</li> <li>2. Follow steps 1–7 for troubleshooting.</li> </ol>
23809	Charger missed the first message from EV	<ol style="list-style-type: none"> <li>1. The charging cable is not locked on the EV side. Unplug, and plug the charging cable in completely until you hear an audible click.</li> <li>2. Follow steps 1–7 for trouble shooting.</li> </ol>
23814	EV side hand shaking feedback incorrect	<ol style="list-style-type: none"> <li>1. Unplug the charging cable, restart BMS on the EV side, and try again.</li> <li>2. Follow steps 1–7 for troubleshooting.</li> </ol>
23844	EV side V2G communication timeout	<ol style="list-style-type: none"> <li>1. Unplug the charging cable, restart BMS on the EV side, and try again.</li> <li>2. Follow steps 1–7 for troubleshooting.</li> </ol>
23847	Charging cable insulation test timeout	<ol style="list-style-type: none"> <li>1. Unplug the charging cable and try again.</li> <li>2. Unplug the charging cable, restart the charger, and try again.</li> </ol>
23889	Noise interference or charging terminated from EV side causes control guide status error	<ol style="list-style-type: none"> <li>1. Please unplug the charging cable, restart BMS on the EV side, and try again.</li> <li>2. Please follow steps 1–7 for troubleshooting.</li> </ol>
23891	Charger not ready	<ol style="list-style-type: none"> <li>1. Please unplug the charging cable, wait for 5 seconds, and try again.</li> <li>2. Please unplug the charging cable, restart the charger, and try again.</li> </ol>
23983	Charging terminated by unknown request from EV	<ol style="list-style-type: none"> <li>1. Check whether charging target or time is limited.</li> <li>2. Follow the EV operating indication for troubleshooting.</li> <li>3. Please unplug the charging cable, restart BMS on the EV side, and try again.</li> </ol>

## 6.3.7 (033-XXX) Troubleshooting

### Message Code from Charger Network

033-XXX contains messages from the charger control server running intelligent remote control. Please follow the remote procedure or contact management staff to arrange for charging.

Status Code	Conditions	Description
033900 033901 033902	Back-end disconnected for the moment	<ol style="list-style-type: none"> <li>Code scanning and app authorization is unavailable for the moment, change to RFID or others authorization.</li> <li>Contact management staff to check Back-end server connectivity.</li> <li>If the connection cannot be restored after router or AP restart, restart the main/sub cabinets.</li> <li>If the connection cannot be restored after main/sub cabinet restart, turn off the whole charger and restart.</li> <li>Contact your dealer.</li> </ol>
033903	Charging started remotely	<ol style="list-style-type: none"> <li>Remote authorization passed, please plug in the charging cable for charging.</li> <li>Contact management staff for further instructions.</li> </ol>
033904	Charging stopped remotely	<ol style="list-style-type: none"> <li>Charging meets setup time, Watt-Hour or amount, charging terminated remotely</li> <li>Contact management staff for further instructions.</li> </ol>
033905	Restart by remotely	<ol style="list-style-type: none"> <li>Remote charger reset and maintenance process by remote control, charging terminated.</li> <li>Contact management staff for further instructions.</li> </ol>

## 6.4 Status Codes

\*For the latest status codes, please visit our website.

(V0.48)

Status Code	Description
011001	CHAdEMO output fuse blew
011002	CCS output fuse blew
011003	GB output fuse blew
011004	RCD/CCID self-test failure
011005	AC input contactor 1 welding
011006	AC input contactor 1 driving fault
011007	AC input contactor 2 welding
011008	AC input contactor 2 driving fault
011009	AC output relay welding
011010	AC output relay driving fault
011011	CHAdEMO output relay welding
011012	CHAdEMO output relay driving fault
011013	CCS output relay welding
011014	CCS output relay driving fault
011015	GB output relay welding
011016	GB output relay driving fault
011017	AC connector temperature sensor broken
011018	CHAdEMO connector temperature sensor broken
011019	CCS connector temperature sensor broken
011020	GB connector temperature sensor broken
011021	Wi-Fi module broken
011022	3G/4G module broken
011023	Aux. power module broken
011024	Relay control module/smart box broken
011025	CHAdEMO connector lock failure
011026	GB connector lock failure
011027	AC connector lock failure

Status Code	Description
011028	CHAdEMO module broken
011029	CCS module broken
011030	GBT module broken
011031	PSU module broken
011032	RCD/CCID module broken
011033	Maximum Output Current setup error
011034	Shutter fault
011035	BLE module broken
011036	Rotary switch fault
011037	CCS liquid chiller water level fault
011038	Chiller temperature sensor broken
011039	Parallel relay welding
011040	Parallel output relay driving fault
012200	System L1 input OVP
012201	System L2 input OVP
012202	System L3 input OVP
012203	System L1 input UVP
012204	System L2 input UVP
012205	System L3 input UVP
012206	PSU L1 input OVP
012207	PSU L2 input OVP
012208	PSU L3 input OVP
012209	PSU L1 input UVP
012210	PSU L2 input UVP
012211	PSU L3 input UVP
012212	System L1 input drop
012213	System L2 input drop
012214	System L3 input drop
012215	System AC output OVP
012216	System AC L1 output OCP

Status Code	Description
012217	System CHAdeMO output OVP
012218	System CHAdeMO output OCP
012219	System CCS output OVP
012220	System CCS output OCP
012221	System GB output OVP
012222	System GB output OCP
012223	System ambient/inlet OTP
012224	System critical point OTP
012225	PSU ambient/inlet OTP
012226	PSU critical point OTP
012227	Aux. power module OTP
012228	Relay board/smart box OTP
012229	CHAdeMO connector OTP
012230	CCS connector OTP
012231	GB connector OTP
012232	AC connector OTP
012233	RCD/CCID trip
012234	CHAdeMO GFD trip
012235	CCS GFD trip
012236	GB GFD trip
012237	SPD trip
012238	Main power breaker trip
012239	Aux. power breaker trip
012240	PSU communication failure
012241	Wi-Fi module communication failure
012242	3G/4G module communication failure
012243	RFID module communication failure
012244	Bluetooth module communication failure
012245	LCM module communication failure
012246	Aux. power module communication failure

Status Code	Description
012247	Relay control board/smart box communication failure
012248	CCS module communication failure
012249	CHAdEMO module communication failure
012250	GBT module communication failure
012251	Emergency stop
012253	System fan decay
012254	Fail to create share memory
012255	CSU initialization failed
012256	AC Ground Fault
012257	MCU self-test Fault
012258	Relay self-test Fault
012259	CHAdEMO ground fault detection timeout (GFD)
012260	CCS ground fault detection timeout (GFD)
012261	GB/T ground fault detection timeout (GFD)
012262	System AC L1 output Circuit Short
012263	PSU Duplicate ID
012264	PSU Output Short Circuit
012265	PSU Discharge Abnormal
012266	PSU Dc Side Shutdown
012267	PSU Failure Alarm
012268	PSU Protection Alarm
012269	PSU Fan Failure Alarm
012270	PSU Input UVP
012271	PSU Input OVP
012272	PSU WalkIn State
012273	PSU Power Limited State
012274	PSU Id Repeat
012275	PSU Severe Uneven Current
012276	PSU Three Phase Input Inadequate
012277	PSU Three Phase Input Imbalance

Status Code	Description
012278	PSU Pfc Side Shutdown
012279	NO PSU Resource
012280	Self-test failed due to communication of Relay board failure
012281	Self-test failed due to communication of Fan board failure
012282	Self-test failed due to communication of Primary (STM of DCM) failure
012283	Self-test failed due to communication of CHAdeMO board failure
012284	Self-test failed due to communication of CCS board failure
012285	Self-test failed due to AC Contact failure
012286	Self-test failed due to communication of PSU failure
012287	Self-test failed due to Model name is none match
012288	CCS output UVP
012289	CHAdeMO output UVP
012290	GBT output UVP
012291	Self-test failed due to communication of GBT board failure
012292	Self-test failed due to communication of AC failure
012293	Self-test failed due to communication of LED board failure
012294	AC input OVP
012295	AC input UVP
012296	CHAdeMO ground fault detection - warning
012297	CCS ground fault detection - warning
012298	GBT ground fault detection - warning
012299	System AC L2 output OCP
012300	System AC L3 output OCP
012301	System AC L2 output Circuit Short
012302	System AC L3 output Circuit Short
012303	CCS liquid chiller water level warning
012304	Disconnected from power cabinet
012305	Meter communication timeout
012306	The dip switch of the PSU may be incorrect
012307	PSU Fuse Burn-Out



Status Code	Description
012308	PSU Pfc And Dcdc Communication Fault
012309	PSU Bus Voltage Unbalance
012310	PSU Bus Over Voltage
012311	PSU Bus Voltage Abnormal
012312	PSU Bus Under Voltage
012313	PSU input phase loss
012314	PSU Fan Full Speed
012315	PSU Temperature power limit
012316	PSU AC Power Limit
012317	PSU Dcdc Eeprom fault
012318	PSU Pfc Eeprom fault
012319	PSU Dcdc over voltage
012320	System CHAdeMO output UCP
012321	System CCS output UCP
012322	System GBT output UCP
012323	System Chiller output OTP
012324	Connector 1 detects abnormal voltage on the output line
012325	Connector 2 detects abnormal voltage on the output line
012326	System task is lost
012327	DC input ovp
012328	DC input uvp
012329	Psu Can Communication Fault
012330	Psu Dc to Dc OTP
012331	Psu Dc to Dc OVP
012344	Meter IC communication timeout
012345	Pilot negative error
012346	Psu Communication error with CSU
013600	Normal stop charging by user
013601	Charging Time's up
013602	Replace system air filter

Status Code	Description
013603	Reach to CHAdeMO max. plugging times.
013604	Reach to CCS max. plugging times
013605	Reach to GBT max. plugging times
013606	Reach to AC max. plugging times
013607	CSU firmware update failed
013608	CHAdeMO Module firmware update failed
013609	CCS Module firmware update failed
013610	GB Module firmware update failed
013611	Aux. power module firmware update failed
013612	Relay control module firmware update failed
013613	LCM module firmware update failed
013614	Bluetooth module firmware update failed
013615	Wi-Fi module firmware update failed
013616	3G/4G module firmware update failed
013617	SMR firmware update failed
013618	RFID module firmware update failed
013619	Configured by USB flash drive
013620	Configured by backend
013621	Configured by web page
013622	Disconnected from Internet through Ethernet
013623	Disconnected from Internet through Wi-Fi
013624	Disconnected from Internet through 3G/4G
013625	Disconnected from AP through Wi-Fi
013626	Disconnected from APN through 3G/4G
013627	WiFi disabled (separated charger only)
013628	4G disabled (separated charger only)
013629	PSU quantity not match
023700	CHAdeMO EV communication failure
023701	CCS EV communication failure
023702	GBT EV communication failure

Status Code	Description
023703	AC: pilot fault
023704	CHAdEMO: battery malfunction
023705	CHAdEMO: no charging permission
023706	CHAdEMO: battery incompatibility
023707	CHAdEMO: battery OVP
023708	CHAdEMO: battery UVP
023709	CHAdEMO: battery OTP
023710	CHAdEMO: battery current difference
023711	CHAdEMO: battery voltage difference
023712	CHAdEMO: shift position
023713	CHAdEMO: battery other fault
023714	CHAdEMO: charging system error
023715	CHAdEMO: EV normal stop
023716	CHAdEMO: connector temperature sensor broken
023717	CHAdEMO: connector lock failure
023718	CHAdEMO: d1 on no receive
023719	CHAdEMO: BMS k to j on timeout
023720	CHAdEMO: BMS charge allow timeout
023721	CHAdEMO: wait ground fault timeout
023722	CHAdEMO: BMS EV relay on timeout
023723	CHAdEMO: BMS req current timeout
023724	CHAdEMO: BMS k to j off timeout
023725	CHAdEMO: BMS EV relay off timeout
023726	CHAdEMO: ADC more than 10v
023727	CHAdEMO: ADC more than 20v
023728	CHAdEMO: BMS charge before stop
023729	CHAdEMO: charger received normal stop command
023730	CHAdEMO: charger received emergency stop command
023731	CHAdEMO: isolation result failure
023732	CHAdEMO: mother board miss link

Status Code	Description
023733	CHAdEMO: output voltage more than limit
023734	CHAdEMO: require current more than limit
023735	CHAdEMO: re capability BMS eqr current exceeded
023736	CHAdEMO: charge remaining count done
023737	CCS: EVCC EVErrorCode FAILED_RESSTemperatureInhibit
023738	CCS: EVCC EVErrorCode_FAILED_EVShiftPosition
023739	CCS: EVCC EVErrorCode FAILED_ChargerConnectorLockFault
023740	CCS: EVCC EVErrorCode FAILED_EVRESSMalfunction
023741	CCS: EVCC EVErrorCode FAILED_ChargingCurrentdifferential
023742	CCS: EVCC EVErrorCode_FAILED_ChargingVoltageOutOfRange
023743	CCS: EVCC EVErrorCode_FAILED_ChargingSystemIncompatibility
023744	CCS: EVCC EVErrorCode_FAILED_EmergencyEvent
023745	CCS: EVCC EVErrorCode_FAILED_Breaker
023746	CCS: EVCC EVErrorCode_FAILED_NoData
023747	CCS: EVCC EVErrorCode_FAILED_reserved_by_DIN_A
023748	CCS: EVCC EVErrorCode_FAILED_reserved_by_DIN_B
023749	CCS: EVCC EVErrorCode_FAILED_reserved_by_DIN_C
023750	CCS: EVCC EVErrorCode_FAILED_reserved_by_ISO_1
023751	CCS: EVCC EVErrorCode_FAILED_reserved_by_ISO_2
023752	CCS: EVCC EVErrorCode_FAILED_reserved_by_ISO_3
023753	CCS: EVCC EVErrorCode_FAILED_reserved_by_OEM_1
023754	CCS: EVCC EVErrorCode_FAILED_reserved_by_OEM_2
023755	CCS: EVCC EVErrorCode_FAILED_reserved_by_OEM_3
023756	CCS: EVCC EVErrorCode_FAILED_reserved_by_OEM_4
023757	CCS: EVCC EVErrorCode_FAILED_reserved_by_OEM_5
023758	CCS: SECC ResponseCode_FAILED_SequenceError
023759	CCS: SECC ResponseCode_FAILED_SignatureError
023760	CCS: SECC ResponseCode_FAILED_UnknownSession
023761	CCS: SECC ResponseCode_FAILED_ServiceIDInvalid
023762	CCS: SECC ResponseCode_FAILED_Payment SelectionInvalid

Status Code	Description
023763	CCS: SECC ResponseCode_FAILED_IdentificationSelectionInvalid
023764	CCS: SECC ResponseCode_FAILED_ServiceSelectionInvalid
023765	CCS: SECC ResponseCode_FAILED_CertificateExpired
023766	CCS: SECC ResponseCode_FAILED_CertificateNotYetValid
023767	CCS: SECC ResponseCode_FAILED_CertificateRevoked
023768	CCS: SECC ResponseCode_FAILED_NoCertificateAvailable
023769	CCS: SECC ResponseCode_FAILED_CertChainError
023770	CCS: SECC ResponseCode_FAILED_CertValidationError
023771	CCS: SECC ResponseCode_FAILED_CertVerificationError
023772	CCS: SECC ResponseCode_FAILED_ContractCanceled
023773	CCS: SECC ResponseCode_FAILED_ChallengeInvalid
023774	CCS: SECC ResponseCode_FAILED_WrongEnergyTransferMode
023775	CCS: SECC ResponseCode_FAILED_WrongChargeParameter
023776	CCS: SECC ResponseCode_FAILED_ChargingProfileInvalid
023777	CCS: SECC ResponseCode_FAILED_TariffSelectionInvalid
023778	CCS: SECC ResponseCode_FAILED_EVSEPresentVoltageTooLow
023779	CCS: SECC ResponseCode_FAILED_PowerDeliveryNotApplied
023780	CCS: SECC ResponseCode_FAILED_MeteringSignatureNotValid
023781	CCS: SECC ResponseCode_FAILED_NoChargeServiceSelected
023782	CCS: SECC ResponseCode_FAILED_ContactorError
023783	CCS: SECC ResponseCode_FAILED_CertificateNotAllowedAtThisEVSE
023784	CCS: SECC ResponseCode_FAILED_GAChargeStop
023785	CCS: SECC ResponseCode_FAILED_AlignmentError
023786	CCS: SECC ResponseCode_FAILED_ACDError
023787	CCS: SECC ResponseCode_FAILED_AssociationError
023788	CCS: SECC ResponseCode_FAILED_EVSEChargeAbort
023789	CCS: SECC ResponseCode_FAILED_NoSupportedApp-Protocol
023790	CCS: SECC ResponseCode_FAILED_ContractNotAccepted
023791	CCS: SECC ResponseCode_FAILED_MOUnknown
023792	CCS: SECC ResponseCode_FAILED_OEM_Prov_CertificateRevoked

Status Code	Description
023793	CCS: SECC ResponseCode_FAILED_OEM_SubCA1_CertificateRevoked
023794	CCS: SECC ResponseCode_FAILED_OEM_SubCA2_CertificateRevoked
023795	CCS: SECC ResponseCode_FAILED_OEM_RootCA_CertificateRevoked
023796	CCS: SECC ResponseCode_FAILED_MO_Prov_CertificateRevoked
023797	CCS: SECC ResponseCode_FAILED_MO_SubCA1_CertificateRevoked
023798	CCS: SECC ResponseCode_FAILED_MO_SubCA2_CertificateRevoked
023799	CCS: SECC ResponseCode_FAILED_MO_RootCA_CertificateRevoked
023800	CCS: SECC ResponseCode_FAILED_CPS_Prov_CertificateRevoked
023801	CCS: SECC ResponseCode_FAILED_CPS_SubCA1_CertificateRevoked
023802	CCS: SECC ResponseCode_FAILED_CPS_SubCA2_CertificateRevoked
023803	CCS: SECC ResponseCode_FAILED_CPS_RootCA_CertificateRevoked
023804	CCS: SECC ResponseCode_FAILED_reserved_1
023805	CCS: SECC ResponseCode_FAILED_reserved_2
023806	CCS: SECC ResponseCode_FAILED_reserved_3
023807	CCS: SECC ResponseCode_FAILED_reserved_4
023808	CCS: SECC ResponseCode_FAILED_reserved_5
023809	CCS: SECC TIMEOUT_SLAC_TT_EVSE_SLAC_init
023810	CCS: SECC TIMEOUT_SLAC_TP_match_response
023811	CCS: SECC TIMEOUT_CM_START_ATTEN_CHAR_IND
023812	CCS: SECC TIMEOUT_SLAC_TT_EVSE_match_MNBC
023813	CCS: SECC TIMEOUT_SLAC_TP_EVSE_avg_atten_calc
023814	CCS: SECC TIMEOUT_SLAC_CM_ATTEN_CHAR_RSP
023815	CCS: SECC TIMEOUT_SLAC_CM_VALIDATE_REQ_1ST__CM_SLAC_MATCH_REQ
023816	CCS: SECC TIMEOUT_SLAC_TT_EVSE_assoc_session
023817	CCS: SECC TIMEOUT_SLAC_TT_EVSE_vald_toggle
023818	CCS: SECC TIMEOUT_SLAC_CM_MNBC_SOUND_IND
023819	CCS: SECC TIMEOUT_SLAC_CM_VALIDATE_REQ_2ND__CM_SLAC_MATCH_REQ
023820	CCS: SECC TIMEOUT_SLAC_reserved_3
023821	CCS: SECC TIMEOUT_SLAC_reserved_4

Status Code	Description
023822	CCS: SECC TIMEOUT_SLAC_reserved_5
023823	CCS: SECC TIMEOUT_SLACC_SDP_UDP_TT_match_join
023824	CCS: SECC TIMEOUT_SLACC_SDP_TCP_TT_match_join
023825	CCS: SECC TIMEOUT_SLACC_SDP_TP_amp_map_exchange
023826	CCS: SECC TIMEOUT_SLACC_SDP_TP_link_ready_notification
023827	CCS: SECC TIMEOUT_SLACC_SDP_reserved_1
023828	CCS: SECC TIMEOUT_SLACC_SDP_reserved_2
023829	CCS: SECC TIMEOUT_SLACC_SDP_reserved_3
023830	CCS: SECC TIMEOUT_SLACC_SDP_reserved_4
023831	CCS: SECC TIMEOUT_SLACC_SDP_reserved_5
023832	CCS: SECC TIMEOUT_V2G_Msg_Performance_Time_SupportedAppProtocolRes
023833	CCS: SECC TIMEOUT_V2G_Msg_Performance_Time_SessionSetupRes
023834	CCS: SECC TIMEOUT_V2G_Msg_Performance_Time_ServiceDiscoveryRes
023835	CCS: SECC TIMEOUT_V2G_Msg_Performance_Time_ServicePaymentSelectionRes
023836	CCS: SECC TIMEOUT_V2G_Msg_Performance_Time_ContractAuthenticationRes
023837	CCS: SECC TIMEOUT_V2G_Msg_Performance_Time_ChargeParameterDiscoveryRes
023838	CCS: SECC TIMEOUT_V2G_Msg_Performance_Time_PowerDeliveryRes
023839	CCS: SECC TIMEOUT_V2G_Msg_Performance_Time_CableCheckRes
023840	CCS: SECC TIMEOUT_V2G_Msg_Performance_Time_PreChargeRes
023841	CCS: SECC TIMEOUT_V2G_Msg_Performance_Time_CurrentDemandRes
023842	CCS: SECC TIMEOUT_V2G_Msg_Performance_Time_WeldingDetectionRes
023843	CCS: SECC TIMEOUT_V2G_Msg_Performance_Time_SessionStopRes
023844	CCS: SECC TIMEOUT_V2G_Sequence_Time
023845	CCS: SECC TIMEOUT_V2G_ReadyToCharge_Performance_Time
023846	CCS: SECC TIMEOUT_V2G_CommunicationSetup_Performance_Time
023847	CCS: SECC TIMEOUT_V2G_CableCheck_Performance_Time

Status Code	Description
023848	CCS: SECC TIMEOUT_V2G_CPState_Detection_Time
023849	CCS: SECC TIMEOUT_V2G_CPOscillator_Retain_Time
023850	CCS: SECC TIMEOUT_V2G_PreCharge_Performace_Time
023851	CCS: SECC TIMEOUT_V2G_reserved_2
023852	CCS: SECC TIMEOUT_V2G_reserved_3
023853	CCS: SECC TIMEOUT_V2G_reserved_4
023854	CCS: SECC TIMEOUT_V2G_reserved_5
023855	CCS: CAN TIMEOUT_TP_GET_EV_TARGET_INFO
023856	CCS: CAN TIMEOUT_TT_GET_EV_TARGET_INFO
023857	CCS: CAN TIMEOUT_TP_GET_EV_BATTERY_INFO
023858	CCS: CAN TIMEOUT_TT_GET_EV_BATTERY_INFO
023859	CCS: CAN TIMEOUT_TP_EV_STOP_EVENT
023860	CCS: CAN TIMEOUT_TT_EV_STOP_EVENT
023861	CCS: CAN TIMEOUT_TP_EVSE_STOP_EVENT
023862	CCS: CAN TIMEOUT_TT_EVSE_STOP_EVENT
023863	CCS: CAN TIMEOUT_TP_GET_MISC_INFO
023864	CCS: CAN TIMEOUT_TT_GET_MISC_INFO
023865	CCS: CAN TIMEOUT_TP_DOWNLOAD_REQUEST
023866	CCS: CAN TIMEOUT_TT_DOWNLOAD_REQUEST
023867	CCS: CAN TIMEOUT_TP_START_BLOCK_TRANSFER
023868	CCS: CAN TIMEOUT_TT_START_BLOCK_TRANSFER
023869	CCS: CAN TIMEOUT_TP_DATA_TRANSFER
023870	CCS: CAN TIMEOUT_TT_DATA_TRANSFER
023871	CCS: CAN TIMEOUT_TP_DOWNLOAD_FINISH
023872	CCS: CAN TIMEOUT_TT_DOWNLOAD_FINISH
023873	CCS: CAN TIMEOUT_TP_ISOLATION_STATUS
023874	CCS: CAN TIMEOUT_TT_ISOLATION_STATUS
023875	CCS: CAN TIMEOUT_TP_CONNECTOR_INFO
023876	CCS: CAN TIMEOUT_TT_CONNECTOR_INFO
023877	CCS: CAN TIMEOUT_TT_RTC_INFO



Status Code	Description
023878	CCS: CAN TIMEOUT_TP_RTC_INFO
023879	CCS: CAN TIMEOUT_TP_EVSE_PRECHARGE_INFO
023880	CCS: CAN TIMEOUT_TT_EVSE_PRECHARGE_INFO
023881	CCS: CAN TIMEOUT_MSG_Sequence
023882	CCS: CAN MSG_Unrecognized_CMD_ID
023883	CCS: SECC DIN_Msg_Decode_Error
023884	CCS: SECC DIN_Msg_Encode_Error
023885	CCS: SECC ISO1_Msg_Decode_Error
023886	CCS: SECC ISO1_Msg_Encode_Error
023887	CCS: SECC ISO2_Msg_Decode_Error
023888	CCS: SECC ISO2_Msg_Encode_Error
023889	CCS: SECC CP_State_Error
023890	CCS: SECC Unexpected_60V_Before_Charging_Error
023891	CCS: SECC Not_Ready_For_Charging
023892	CCS: SECC TIMEOUT_QCA7000_COMM (The firmware code QCA7000 may not yet be installed.)
023893	CCS: SECC FAIL_QCA7000_SETKEY
023900	GBT_LOS_CC1
023901	GBT_CONNECTOR_LOCK_FAIL
023902	GBT_BATTERY_INCOMPATIBLE
023903	GBT_BMS_BROAA_TIMEOUT
023904	GBT_CSU_PRECHARGE_TIMEOUT
023905	GBT_BMS_PRESENT_VOLTAGE_FAULT
023906	GBT_BMS_VOLTAGE_OVER_RANGE
023907	GBT_BSM_CHARGE_ALLOW_00_10MIN_COUUNTDONE
023908	GBT_WAIT_GROUNDFULT_TIMEOUT
023909	GBT_ADC_MORE_THAN_10V
023910	GBT_ADC_MORE_THAN_60V
023911	GBT_CHARGER_GET_NORMAL_STOP_CMD
023912	GBT_CHARGER_GET_EMERGENCY_STOP_CMD

Status Code	Description
023913	GBT_ISOLATION_RESULT_FAIL
023914	GBT_MOTHER_BOARD_MISS_LINK
023915	GBT_OUTPUT_VOLTAGE_MORE_THAN_LIMIT
023916	GBT_REQ_CURRENT_MORE_THAN_LIMIT
023917	GBT_OUTPUT_VOLTAGE_MORE_THAN_10_PERCENT
023918	GBT_OUTPUT_VOLTAGE_DIFF_BCS_5_PERCENT
023919	GBT_STOP_ADC_MORE_THAN_10V
023920	ERROR_CODE_GBT_BMS_BROAA_NO_VOLTAGE_TIMEOUT
023921	ERROR_CODE_GBT_BMS_BROAA_TO_BRO00_ERROR
023930	GBT_CEM_BHM_TIMEOUT
023931	GBT_CEM_BRM_TIMEOUT
023932	GBT_CEM_BCP_TIMEOUT
023933	GBT_CEM_BRO_TIMEOUT
023934	GBT_CEM_BCL_TIMEOUT
023935	GBT_CEM_BCS_TIMEOUT
023936	GBT_CEM_BSM_TIMEOUT
023937	GBT_CEM_BST_TIMEOUT
023938	GBT_CEM_BSD_TIMEOUT
023939	GBT_CEM_BEM_OTHER_TIMEOUT
023940	GBT_BEM_CRM_TIMEOUT
023941	GBT_BEM_CRMAA_TIMEOUT
023942	GBT_BEM_CTS_CML_TIMEOUT
023943	GBT_BEM_CRO_TIMEOUT
023944	GBT_BEM_CCS_TIMEOUT
023945	GBT_BEM_CST_TIMEOUT
023946	GBT_BEM_CSD_TIMEOUT
023947	GBT_BEM_BEM_OTHER_TIMEOUT
023950	GBT_BST_SOC_GOAL
023951	GBT_BST_TOTAL_VOLTAGE_GOAL
023952	GBT_BST_CELL_VOLTAGE_GOAL

Status Code	Description
023953	GBT_BST_GET_CST
023954	GBT_BST_ISOLATION
023955	GBT_BST_OUTPUT_CONNECTOR_OTP
023956	GBT_BST_COMPONENT
023957	GBT_BST_CHARGE_CONNECTOR
023958	GBT_BST_OTP
023959	GBT_BST_OTHER
023960	GBT_BST_HIGH_V
023961	GBT_BST_CC2
023962	GBT_BST_CURRENT
023963	GBT_BST_VOLTAGE
023964	GBT_GET_BST_NO_REASON
023970	GBT_BSM_CELL_OVER_VOLTAGE
023971	GBT_BSM_CELL_UNDER_VOLTAGE
023972	GBT_BSM_OVER_SOC
023973	GBT_BSM_UNDER_SOC
023974	GBT_BSM_CURRENT
023975	GBT_BSM_TEMPERATURE
023976	GBT_BSM_ISOLATE
023977	GBT_BSM_OUTPUT_CONNECTOR
023979	EV full charging
023980	ERROR_CODE_CHADEMO_BMS_CHARGE_ALLOW_ERROR
023981	ERROR_CODE_CHADEMO_OUTPUT_VOLTAGE_MORE_THAN_10_PERCENT
023982	ERROR_CODE_CHADEMO_ADC_LESS_THAN_10V
023983	CCS_ STOP by EV with unknow reason
023984	STOP by EVSE condition (Config or OCPP)
033900	Disconnected from backend through Ethernet
033901	Disconnected from backend through Wi-Fi
033902	Disconnected from backend through 3G/4G

Status Code	Description
033903	Remote start charging by backend
033904	Remote stop charging by backend
033905	Remote reset by backend
041004	RCD/CCID self-test fail
041005	AC input contactor 1 welding
041006	AC input contactor 1 driving fault
041007	AC input contactor 2 welding
041008	AC input contactor 2 driving fault
041009	AC output relay welding
041010	AC output relay driving fault
041017	AC connector temperature sensor broken
041021	WiFi module broken
041022	3G/4G module broken
041023	Aux. power module broken
041024	Relay control module /smart box broken
041031	PSU module broken
041032	RCD/CCID module broken
041033	Maximum Output Current setup error
041034	Shutter fault
041035	Ble module broken
041036	Rotary switch fault
042200	System L1 input OVP
042201	System L2 input OVP
042202	System L3 input OVP
042203	System L1 input UVP
042204	System L2 input UVP
042205	System L3 input UVP
042206	PSU L1 input OVP
042207	PSU L2 input OVP

Status Code	Description
042208	PSU L3 input OVP
042209	PSU L1 input UVP
042210	PSU L2 input UVP
042211	PSU L3 input UVP
042212	System L1 input drop
042213	System L2 input drop
042214	System L3 input drop
042223	System ambient/inlet OTP
042224	System critical point OTP
042225	PSU ambient/inlet OTP
042226	PSU critical point OTP
042227	Aux. power module OTP
042228	Relay board/smart box OTP
042232	AC connector OTP
042233	RCD/CCID trip
042237	SPD trip
042238	Main power breaker trip
042239	Aux. power breaker trip
042240	PSU communication fail
042241	WiFi module communication fail
042242	3G/4G module communication fail
042244	Bluetooth module communication fail
042246	Aux. power module communication fail
042247	Relay control board/smart box communication fail
042251	Emergency stop
042252	Door open
042253	System fan decay
042254	Fail to create share memory
042255	CSU initialization failed
042257	MCU self-test Fault

Status Code	Description
042258	Relay self-test Fault
042262	System AC L1 output Circuit Short
042263	PSU Duplicate ID
042264	PSU Output Short Circuit
042265	PSU Discharge Abnormal
042266	PSU Dc Side ShutDown
042267	PSU Failure Alarm
042268	PSU Protection Alarm
042269	PSU FanFailure Alarm
042270	PSU Input UVP
042271	PSU Input OVP
042272	PSU WalkIn State
042273	PSU Power Limited State
042274	PSU Id Repeat
042275	PSU Severe Uneven Current
042276	PSU Three Phase Input Inadequate
042277	PSU Three Phase Onput Imbalance
042278	PSU Ffc Side ShutDown
042279	NO PSU Resource
042280	Self test Failed due to communication of Relayboard failure
042281	Self test Failed due to communication of Fanboard failure
042282	Self test Failed due to communication of Primary failure
042283	Self test Failed due to communication of Chademoboard failure
042284	Self test Failed due to communication of CCSboard failure
042285	Self test Failed due to AC Contact failure
042286	Self test Failed due to communication of PSU failure
042287	Self test Failed due to Model name is none match
042291	Self test Failed due to communication of GBTboard failure
042292	Self test Failed due to communication of AC failure
042293	Self test Failed due to communication of Ledboard failure

Status Code	Description
042294	AC input ovp
042295	AC input uvp
042299	System AC L2 output OCP
042300	System AC L3 output OCP
042301	System AC L2 output Circuit Short
042302	System AC L3 output Circuit Short
042304	disconnected from dispenser
042305	Meter communication timeout
042306	The dip switch of the PSU may be incorrect
042307	Psu Fuse Burn-Out
042308	Psu Pfc And Dcdc Communication Fault
042309	Psu Bus Voltage Unbalance
042310	Psu Bus Over Voltage
042311	Psu Bus Voltage Abnormal
042312	Psu Bus Under Voltage
042313	Psu Input Phase Loss
042314	Psu Fan Full Speed
042315	Psu Temperature Power Limit
042316	Psu Ac Power Limit
042317	Psu Dcdc Eeprom Fault
042318	Psu Pfc Eeprom Fault
042319	Psu Dcdc Over Voltage
042326	System task is lost
042327	DC input ovp
042328	DC input uvp
043600	Normal stop charging by user
043601	Charging Time's up
043602	Replace system air filter
043607	CSU firmware update fail
043611	Aux. power module firmware update fail

Status Code	Description
043612	Relay control module firmware update fail
043614	Bluetooth module firmware update fail
043615	WiFi module firmware update fail
043616	3G/4G module firmware update fail
043617	SMR firmware update fail
043618	RFID module firmware update fail
043619	configured by USB flash drive
043620	configured by backend
043621	configured by webpage
043622	disconnected from Internet through Ethernet
043623	disconnected from Internet through WiFi
043624	disconnected from Internet through 3G/4G
043625	disconnected from AP through WiFi
043626	disconnected from APN through 3G/4G
043627	WiFi disabled (separated charger only)
043628	4G disabled (separated charger only)
043629	PSU quantity not match



# 7. Maintenance

## 7.1 General Maintenance

- The DC Fast Charger is cooled by forced air. Please keep charger in a ventilated location and do not block the air vents in the DC Fast Charger.
- Please clean or replace the air filters regularly to ensure the DC Fast Charger works properly.
- Clean the DC Fast Charger at least three times a year, and keep the exterior clean at all times.
- Clean the outside of the cabinet with a damp cloth or wet cotton towel, only use low-pressure tap water and cleaning agents with a PH level between 6 and 8.
- Do not apply high-pressure water jets.
- Do not use cleaning agents with abrasive components and do not use abrasive tools. Improper cleaning agents might spoil the coating, paint, surface, brightness and durability of all exterior parts.
- If there is water intruding into the DC Fast Charger, then please cut off the power source immediately and contact the DC Fast Charger provider for repair.
- Please make sure the charging connector is returned to its holder after charging to prevent damage.
- If there is damage to the charging connector, charging cable charging connector holder, then please contact the DC Fast Charger provider.
- When using the DC Fast Charger, please handle properly. Do not strike or scrape the cabinet or touch screen.
- If the enclosure or screen is broken, cracked, open or shows any other indication of damage, then please contact the DC Fast Charger provider.



**WARNING:** Danger of electrical shock or injury. Turn OFF power at the panelboard or load center before working on the equipment or removing any component. Do not remove circuit protective devices or any other component until the power is turned OFF.

- Disconnect electrical power to the DC Fast Charger before any maintenance work to ensure it is separated from the supply of AC mains. Failure to do so may cause physical injury or damage to the electrical system and charging unit.

Note:

- Before switching off the main breaker to begin maintenance, please record the status code number on the LCD monitor.
- After the maintenance door is opened or the charger NFB is turned off, the charger is still hazardous. Only do visual inspections.
- Maintenance of the DC Fast Charger shall be conducted only by a qualified technician.
- After opening the front door of the DC Fast Charger, turn off the main breaker and auxiliary breaker before beginning any maintenance work.
- Replace the ventilation filter every six to twelve months.
- Please confirm the main power junctions are tightened every month, and rotate cables testing when the power off. If any main power screw is loose, the charger will be damaged or contain smoke on the connections. Please confirm screw torque requirement table.
- Charging cable maintenance: Do not twist or bend the charging cable. The metal contact should not fade or be rust.

## Screw torque requirement table

Screw in Metric						
Screw size	Screw type	Steel Inch-Lbs	Steel Kgf-Cm	Steel N-m	Aluminum Kgf-Cm	Aluminum N-m
M2*0.4	Machine	3~4.77	3.5~5.5	0.34~0.54	3~4.5	0.34~0.44
M2.5*0.45	Machine	3~4.77	3.5~5.5	0.34~0.54	3~4.5	0.34~0.44
M3*0.5	Machine	5.5~9	6.5~10.5	0.64~1.04	5.2~8.4	0.51~0.82
M3.5*0.6	Machine	8.5~13	10~15	0.98~1.47	8~12	0.78~1.18
M4*0.7	Machine	13~18	15~21	1.47~2.06	12~17	1.18~1.66
M5*0.8	Machine	25~34	29~39	2.84~3.82	23~32	2.26~3.14
M6*1.0	Machine	45~55	52~63.5	5.1~6.22	42~51	4.11~5
M6*1.0	Hex cap	85~112	98~129	9.6~12.65	78~103	7.65~10.1
M8*1.25	Machine	106~141	122~163	11.96~15.98	98~130	9.61~12.75
M8*1.25	Hex cap	205~274	237~316	23.24~30.98	190~253	18.63~24.8
M10*1.5	Hex cap	212~382	245~440	24.02~43.15	196~351	19.22~34.42
M12*1.75	Hex cap	372~668	430~770	42.17~75.49	343~615	33.63~60.3
Screw in Imperial						
2-56	Machine	1.5~2	1.7~2.3	0.17~0.22	1.4~1.8	0.14~0.18
4-40	Machine	3~4	3.5~4.5	0.34~0.44	2.8~3.6	0.27~0.35
6-32	Machine	6~10	7~11.5	0.68~1.13	5.6~9.2	0.55~0.9
8-32	Machine	10~15	11.5~17	1.13~1.66	9.2~14	0.9~1.37
10-32	Machine	16~24	18.5~28	1.81~2.74	15~22	1.47~2.16
1/4-20	Machine	35~46	40~53	3.92~5.2	32~42	3.14~4.11
1/4-20	Hex cap	57~77	66~89	6.47~8.73	53~71	5.2~6.96
5/16-18	Hex cap	119~158	137~182	13.43~17.85	110~145	10.77~14.21
3/8-16	Hex cap	205~274	237~316	23.24~30.99	190~253	18.63~24.82
7/16-14	Hex cap	338~451	390~521	38.24~51.09	312~416	30.59~40.79
1/2-13	Hex cap	515~686	595~792	58.35~77.66	476~634	46.68~62.17

## 7.2 Replacement Kits and Accessories

The DC EVSE offers the following replacement kits and accessories:

Replacement Kit List
7-inch LCD
CCS1/CHAdEMO 125 Amp (or above) DC charging connector & 4 M charging cable
Charging Cable Holder
Emergency Stop Button
30 kW DC PSU U-1K0100
MW Aux. Power HVG-150-12 A
MW Aux. Power HVG-240-24 A
Control & Supervisory Unit (CSU3.0)
Surge Protection Device (SPD)
DC Fan
Air Filters
Door Key
Gland (M50)
User Manual
Relay Board
Fan Board
LED Board
4G/Wi-Fi Board
DC Relay
AC Contactor
NFB & RCD

## 8. Limited Product Warranty

The product body is made of metal welding and surface painting. When the product is placed in a natural environment, different environmental factors will make the surface appear slightly rusted, possibly during warranty period (E.g., acid deposition). However, it does not affect the charger function.

The warranty period of this charger is in accordance with the purchasing contract is usually two years. Any spare parts provided by the supplier and used as replacements for repair are covered by a five-year guarantee.

Maintenance replacement and repair parts made by alternative manufacturers are only allowed if authorized by the supplier.

Warranty Exclusions:

- Damage or being rendered non-functional as a result of power surges, lighting, earthquake, fire, flood, pest damage, abuse, accident, misuse, negligence or failure to maintain the product or other event beyond the supplier's reasonable control or not arising from normal operating condition.
- Cosmetic or superficial defects, dents, marks or scratches after use.
- Components which are separate from the product, ancillary equipment and consumables, such as the door key, RFID card, air filter, fuse, cable, wires and connectors.
- Damage as a result of modifications, alterations or disassembly that were not pre-authorized in writing by the supplier.
- Damage due to the failure to observe the applicable safety regulations governing the proper use of the product.
- Installation or operation not in strict conformance with the documentation, including without limitation, not ensuring sufficient ventilation for the product as described in the supplier installation instructions.

If a defect in the product arises and a valid claim is received within the warranty period, your sole and exclusive remedy will be for the supplier, at its sole discretion and to extent permitted by law, to

1. Repair the defect in the product at no charge, using new or refurbished parts.
2. Exchange the product with a new or refurbished product that is functionally equivalent to the original product.

Any remedy hardware product will be warranted for the remainder of the original warranty period or 90 days from delivery to the customer, whichever is longer.

In order to receive the remedy set for above, you must contact the supplier during the warranty period and provide the model number, series number, proof of purchase, and date of purchase.

## 9. Federal Communication Commission Interference Statement

This device complies with Part 15 of the FCC Rules. Operation is subject to the following two conditions: (1) This device may not cause harmful interference, and (2) this device must accept any interference received, including interference that may cause undesired operation. This equipment has been tested and found to comply with the limits for a Class B digital device, pursuant to Part 15 of the FCC Rules. These limits are designed to provide reasonable protection against harmful interference in a residential installation. This equipment generates, uses and can radiate radio frequency energy and, if not installed and used in accordance with the instructions, may cause harmful interference to radio communications. However, there is no guarantee that interference will not occur in a particular installation. If this equipment does cause harmful interference to radio or television reception, which can be determined by turning the equipment off and on, the user is encouraged to try to correct the interference by one of the following measures:

- Reorient or relocate the receiving antenna.
- Increase the separation between the equipment and receiver.
- Connect the equipment into an outlet on a circuit different from that to which the receiver is connected.
- Consult the dealer or an experienced radio/TV technician for help.

FCC Caution: Any changes or modifications not expressly approved by the party responsible for compliance could void the user's authority to operate this equipment.

This transmitter must not be co-located or operating in conjunction with any other antenna or transmitter.

### **Radiation Exposure Statement:**

This equipment complies with FCC radiation exposure limits set forth for an uncontrolled environment. This equipment should be installed and operated with a minimum distance 20 cm between the radiator and your body.

## 10. Industry Canada Statement

This device complies with ISED's licence-exempt RSSs. Operation is subject to the following two conditions: (1) This device may not cause harmful interference, and (2) this device must accept any interference received, including interference that may cause undesired operation.

Le présent appareil est conforme aux CNR d'ISED applicables aux appareils radio exempts de licence. L'exploitation est autorisée aux deux conditions suivantes : (1) le dispositif ne doit pas produire de brouillage préjudiciable, et (2) ce dispositif doit accepter tout brouillage reçu, y compris un brouillage susceptible de provoquer un fonctionnement indésirable.

### **Radiation Exposure Statement:**

This equipment complies with ISED radiation exposure limits set forth for an uncontrolled environment. This equipment should be installed and operated with a distance greater than 20 cm between the radiator and your body.

### **Déclaration d'exposition aux radiations:**

Cet équipement est conforme aux limites d'exposition aux rayonnements ISED établies pour un environnement non contrôlé. Cet équipement doit être installé et utilisé à plus de 20 cm entre le radiateur et votre corps.

### **This device is intended only for OEM integrators under the following conditions: (For module device use)**

- (1) The antenna must be installed and operated with a distance greater than 20 cm between the antenna and users, and
- (2) The transmitter module may not be co-located with any other transmitter or antenna.

As long as both conditions above are met, further transmitter tests will not be required. However, the OEM integrator is still responsible for testing their end-product for any additional compliance requirements required with this module installed.

### **Cet appareil est conçu uniquement pour les intégrateurs OEM dans les conditions suivantes: (Pour utilisation de dispositif module)**

- (1) L'antenne doit être installée et exploitée avec plus de 20 cm entre l'antenne et les utilisateurs, et
- (2) Le module émetteur peut ne pas être coimplanté avec un autre émetteur ou antenne.



Tant que les 2 conditions ci-dessus sont remplies, des essais supplémentaires sur l'émetteur ne seront pas nécessaires. Toutefois, l'intégrateur OEM est toujours responsable des essais sur son produit final pour toutes exigences de conformité supplémentaires requis pour ce module installé.

**IMPORTANT NOTE:**

In the event that these conditions cannot be met (for example certain laptop configurations or co-location with another transmitter), then the Canada authorization is no longer considered valid and the IC ID cannot be used on the final product. In these circumstances, the OEM integrator will be responsible for re-evaluating the end product (including the transmitter) and obtaining a separate Canada authorization.

**NOTE IMPORTANTE:**

Dans le cas où ces conditions ne peuvent être satisfaites (par exemple pour certaines configurations d'ordinateur portable ou de certaines co-localisation avec un autre émetteur), l'autorisation du Canada n'est plus considéré comme valide et l'ID IC ne peut pas être utilisé sur le produit final. Dans ces circonstances, l'intégrateur OEM sera chargé de réévaluer le produit final (y compris l'émetteur) et l'obtention d'une autorisation distincte au Canada.

## Appendix - Package list

Item	Description	No.	Remark
1	EVSE	1	
2	User manual	1	
3	EVSE approved certificate	1	
4	OQC report	1	
5	Door Key	1	
6	Base cover	4	
7	M4x8 screw	22	
8	Gun holder	2	
A	Cable management	1	Optional
B	M5x12 screw	6	Optional





Please visit the official website to obtain the latest version of the user manual before installation.

Website: [www.noodoe.com](http://www.noodoe.com)